

Compact Refrigerators & Freezers

400P & 4000P Series

Original Instructions

Installation, Operation and Maintenance Manual

This manual is updated as new information and models are released. Visit our website for the latest manual.



****Note - additional shelves shown above****

 **Caution**

Read this instruction before operating this equipment.

Original Document

Part Number 9294045D 07/22

Safety Notices

⚠ Warning

Read this manual thoroughly before operating, installing or performing maintenance on the equipment. Failure to follow instructions in this manual can cause property damage, injury or death.

⚠ DANGER

Do not install or operate equipment that has been misused, abused, neglected, damaged, or altered/modified from that of original manufactured specifications.

⚠ DANGER

Keep power cord AWAY from HEATED surfaces. DO NOT immerse power cord or plug in water. DO NOT let power cord hang over edge of table or counter.

⚠ DANGER

All utility connections and fixtures must be maintained in accordance with Local and national codes.

⚠ Warning

Authorized Service Representatives are obligated to follow industry standard safety procedures, including, but not limited to, local/national regulations for disconnection / lock out / tag out procedures for all utilities including electric, gas, water and steam.

⚠ Warning

Do not store or use gasoline or other flammable vapors or liquids in the vicinity of this or any other appliance. Never use flammable oil soaked cloths or combustible cleaning solutions, for cleaning.

⚠ Warning

This product contains chemicals known to the State of California to cause cancer and/or birth defects or other reproductive harm. Operation, installation, and servicing of this product could expose you to airborne particles of glasswool or ceramic fibers, crystalline silica, and/or carbon monoxide. Inhalation of airborne particles of glasswool or ceramic fibers is known to the State of California to cause cancer. Inhalation of carbon monoxide is known to the State of California to cause birth defects or other reproductive harm.

⚠ Warning

Do not use electrical appliances inside the food storage compartments of the appliance, unless they are of the type recommended by the manufacturer.

⚠ Warning

Use caution when handling metal surface edges of all equipment.

⚠ Warning

This appliance is not intended for use by persons (including children) with reduced physical, sensory or mental capabilities, or lack of experience and knowledge, unless they have been given supervision concerning use of the appliance by a person responsible for their safety. Do not allow children to play with this appliance.

⚠ Caution

Use caution handling, moving and use of the R290 refrigerators to avoid either damaging the refrigerant tubing or increasing the risk of a leak. Components shall be replaced with like components. Servicing shall be done by a factory authorized service personnel to minimize the risk of possible ignition due to incorrect parts or improper service.

Notice

Proper installation, care and maintenance are essential for maximum performance and trouble-free operation of your equipment. Visit our website www.wbtkitchenare.com for manual updates, translations, or contact information for service agents in your area.

Notice

This product utilizes Ecomate blowing agent methyl formate

Table of Contents

Section 1

General Information

Model Numbers	4
Serial Number Location	4
Warranty Information	4
Regulatory Certifications	4

Section 2

Installation

Location	5
Weight of Equipment	6
Clearance Requirements.....	6
Dimensions	6
Electrical Service	7
Ground Fault Circuit Interrupter	7
Rated Amperages, Horsepower, Voltage & Power Cord Chart.....	7
NOM Ratings.....	8
Refrigeration	9
Drain Connections.....	9
Caster Or Leg Installation	9
Leg Leveling	10
Caster and Leg Mounting Detail.....	10
Loosen Freezer Compressor Bolts.....	10

Section 3

Operation

Carel Control - Standard	13
R290 Refrigerators.....	13
Freezers	13
Evaporator Fan Operation.....	14
Danfoss Control - Export.....	15
Freezer Defrost	15
R290 Display	15
R290 Evaporator Fan Operation.....	16
Changing Display from Fahrenheit to Celsius.....	17

Section 4

Maintenance

Interior Cleaning	19
Preventing Blower Coil Corrosion	19
Exterior Cleaning.....	19
Drain.....	19
Cleaning the Condenser Coil	19
Doors/Hinges.....	19

Section 5

Troubleshooting

Problem -> Cause -> Correction Chart.....	20
Wiring Diagrams.....	21

Section 1

General Information

Model Numbers

This manual covers standard units only.

NOTE: For custom units, consult Welbilt KitchenCare at 1-844-724-CARE.

NOTE: The suffix P on a model number indicates the use of the refrigerant R-290.

Work Top Refrigerator Bases With Stainless Steel Top & Backsplash	
402P	ST4048P

Work Top Freezer Base With Stainless Steel Top & Backsplash	
403P	
403P-ES	

Undercounter Refrigerator Bases With Stainless Steel Top	
406P	UC4048P

Undercounter Refrigerator With Subtop And 3.75" Casters	
406CAP	

Undercounter Freezer Base With Stainless Steel Top	
407P	
407P-ES	

Undercounter Freezer With Subtop And 3.75" Casters	
407CAP	

Export Model Numbers

This manual covers standard units only.

NOTE: For custom units, consult Welbilt KitchenCare at 1-844-724-CARE.

NOTE: The suffix P on a model number indicates the use of the refrigerant R-290.

NOTE:

Undercounter Freezer Base With Stainless Steel Top	
407P-CE1	
407P-CE2	
407P-DHL-CE1	
407P-DHL-CE2	

Serial Number Location

All 400 and 4000 models have the serial tags applied to the left upper sidewall inside the cabinet.

Always have the serial number of your unit available when calling for parts or service.

Warranty Information

Visit



<http://www.delfield.com/warranty> to:

- Register your product for warranty.
- Verify warranty information.
- View and download a copy of your warranty.

Regulatory Certifications



STANDARD MODELS

115Volt, 60Hertz, 1Phase models are certified by:

-  National Sanitation Foundation (NSF)
-  Underwriters Laboratories (UL)
-  Underwriters Laboratories of Canada (cUL)

EXPORT OPTIONS

230-240Volt, 50Hertz, 1Phase models are certified by:

-  National Sanitation Foundation (NSF)
-  Technical Inspection Association
-  European Conformity

Section 2 Installation

⚠ DANGER

Installation must comply with all applicable fire and health codes in your jurisdiction.

⚠ DANGER

Use appropriate safety equipment during installation and servicing

⚠ Warning

Remove all removable panels before lifting and installing.

⚠ Warning

Do not damage the refrigeration circuit when installing, maintaining or servicing the unit.

Location

⚠ Warning

This equipment must be positioned so that the plug is accessible unless other means for disconnection from the power supply (e.g., circuit breaker or disconnect switch) is provided.

⚠ Warning

Adequate means must be provided to limit the movement of this appliance without depending on or transmitting stress to the electrical conduit or gas lines.

⚠ Warning

To avoid instability the installation area must be capable of supporting the combined weight of the equipment and product. Additionally the equipment must be level side to side and front to back.

⚠ Warning

This equipment is intended for indoor use only. Do not install or operate this equipment in outdoor areas.

⚠ Caution

Do not position the air intake vent near steam or heat exhaust of another appliance.

The location selected for the equipment must meet the following criteria. If any of these criteria are not met, select another location.

- Units are intended for indoor use only.
- The location **MUST** be level, stable and capable of supporting the weight of the equipment.
- The location **MUST** be free from and clear of combustable materials.
- Equipment **MUST** be level both front to back and side to side.
- Position the equipment so it will not tip or slide.
- Front casters **MUST** be locked once positioned.
- Recommended air temperature is 41° - 86°F (5° - 30°C).
- Proper air supply for ventilation is **REQUIRED AND CRITICAL** for safe and efficient operation. Refer to Clearance Requirements chart on page 6.
- Do not obstruct the flow of ventilation air. Make sure the air vents of the equipment are not blocked.
- Do not install the equipment directly over a drain. Steam rising up out of the drain will adversely affect operation, air circulation, and damage electrical / electronic components.

Weight of Equipment

Model	Weight
402P	176lbs (80kg)
403P	176lbs (80kg)
406P	176lbs (80kg)
406CAP	168lbs (76kg)
407P	176lbs (80kg)
407CAP	168lbs (76kg)
ST4048P	234lbs (106kg)
UC4048P	236lbs (107kg)
Export	
407P-CE1	176lbs (80kg)
407P-CE2	176lbs (80kg)
407P-DHL-CE1	176lbs (80kg)
407P-DHL-CE2	176lbs (80kg)

Clearance Requirements

DANGER

Minimum clearance requirements are the same for noncombustible locations as for combustible locations. The flooring under the appliance must be made of a noncombustible material.

DANGER

Risk of fire/shock. All minimum clearances must be maintained. Do not obstruct vents or openings.

Back	3.00" (76mm)
Top / Sides	1.00" (25mm)
Bottom	2.00" (51mm)

- Keep the vents clean and free of obstruction.
- Legs or casters must be used and not removed.

Dimensions

Model	Length	Depth	Height
402P	27" (69cm)	28.5" (72cm)	39.5" (100cm)
403P	27" (69cm)	28.5" (72cm)	35.5" (90cm)
406P	27" (69cm)	28.5" (72cm)	35.5" (90cm)
406CAP	27" (69cm)	27.75" (70cm)	33.25" (84cm)
407P	27" (69cm)	28.5" (72cm)	35.5" (90cm)
407CAP	27" (69cm)	27.75" (70cm)	33.25" (84cm)
ST4048P	48" (122cm)	28.5" (72cm)	39.5" (100cm)
UC4048P	48" (122cm)	28.5" (72cm)	35.5" (90cm)
Export			
407P-CE1	27" (69cm)	29.4" (75cm)	35.38" (89cm)
407P-CE2	27" (69cm)	29.4" (75cm)	35.38" (89cm)
407P-DHL-CE1	27" (69cm)	29.4" (75cm)	35.38" (89cm)
407P-DHL-CE2	27" (69cm)	29.4" (75cm)	35.38" (89cm)

Model	Volume	Shelf Space	Shelf Max Load
402P 403P 406P 406CAP 407P 407CAP	5.7Ft ³ (161L)	4.6Ft ² (43dm ²)	124lbs (56kg)
ST4048P UC4048P	10.80Ft ³ (306L)	8.0Ft ² (74dm ²)	88lbs (40kg)
Export			
407P-CE1 407P-CE2 407P-DHL-CE1 407P-DHL-CE2	5.7Ft ³ (161L)	4.6Ft ² (43dm ²)	124lbs (56kg)

Electrical Service

⚠ DANGER

Check all wiring connections, including factory terminals, before operation. Connections can become loose during shipment and installation.

⚠ DANGER

Units with two power cords must be plugged into individual branch circuits. During movement, cleaning or repair it is necessary to unplug both power cords.

⚠ Warning

This appliance must be grounded and all field wiring must conform to all applicable local and national codes. Refer to rating plate for proper voltage. It is the responsibility of the end user to provide the disconnect means to satisfy the authority having jurisdiction.

- Plug units with R290 refrigerant into a receptacle that is a minimum of 14" (36cm) above the floor.
- All electrical work, including wire routing and grounding, must conform to local, state and national electrical codes.
- The equipment must be grounded.
- A separate fuse/circuit breaker must be provided for each unit.
- The maximum allowable voltage variation is ±10% of the rated voltage at equipment start-up (when the electrical load is highest).
- Check all green ground screws, cables and wire connections to verify they are tight before start-up.

GROUND FAULT CIRCUIT INTERRUPTER

Ground Fault Circuit Interrupter (GFCI/GFI) protection is a system that shuts down the electric circuit (opens it) when it senses an unexpected loss of power, presumably to ground. Welbilt does not recommend the use of GFCI/GFI circuit protection to energize our equipment. If code requires the use of a GFCI/GFI then you must follow the local code. The circuit must be dedicated, sized properly and there must be a panel GFCI/GFI breaker. We do not recommend the use of GFCI/GFI outlets to energize our equipment as they are known for more intermittent nuisance trips than panel breakers.

RATED AMPERAGES, HORSEPOWER, VOLTAGE & POWER CORD CHART

Units with plugs are supplied with approximately 6ft (183cm) cords.

Models 406P and 407P may be stacked using a stacking collar. In this case two 6ft (183cm) long grounded supply cords and plugs are standard.

Model	Amps	HP	Voltage, Cycle, Phase	NEMA Plug
402P	2.6	.18	115/60/1	5-15P
403P	4.5	.30		
406P	2.6	.18		
406CAP	2.6	.18		
403P-ES	4.5	.30		
407P	4.5	.30		
407P-ES	4.5	.30		
407CAP	4.5	.30		
ST4048P	2.6	.18		
UC4048P	2.6	.18		
Export				
407P-CE1	3.9	.30	100-120/50-60/1	Variable
407P-CE2	1.9	.30	200-240/50-60/1	
407P-DHL-CE1	3.9	.30	100-120/50-60/1	
407P-DHL-CE2	1.9	.30	200-240/50-60/1	

NOM Ratings

	Modelos	Tensión (V~)	Corriente (A)	Frecuencia (Hz)	Capacidad (L)	Consumo límite (Wh/L)	Consumo de aparato (Wh/L)	Ahorro (%)	Cantidad de
Enfriador Commercial Vertical Puerta Solida	402P	115	2.6	60	161.4	22.1	9.1	58.8	99
	406P								
	406P-STAR								
	406CAP								
	UC4048P				308.6	16.5	5.7	65.4	
	UC4048P-STAR								
	ST4048P								
Congelador Commercial Vertical Con Puerta Solida	403P	4.5	161.4	39.5	16.0	74	74		
	407P								
	407CAP							16.2	

Refrigeration

Model	BTU/Hour Capacity	Heat of Rejection	Refr Charge
402P	1276	177	68g R290
403P	922	542	68g R290
403P-ES	922	542	68g R290
406P	1276	177	68g R290
406CAP	1276	177	68g R290
407P	922	542	68g R290
407P	922	542	68g R290
407CAP	922	542	68g R290
ST4048P	1276	452	68g R290
UC4048P	1276	452	68g R290
Export			
407P-CE1	922	542	150g R290
407P-CE2	922	542	150g R290
407P-DHL-CE1	922	542	150g R290
407P-DHL-CE2	922	542	150g R290

Drain Connections

⚠ Warning

If a refrigerated base does not have a condensate evaporator supplied, you must connect the condensate line to a suitable drain. Otherwise, water will collect on the floor, causing a potentially hazardous situation.

⚠ Warning

Moisture collecting from improper drainage can create a slippery surface on the floor and a hazard to employees. It is the owner’s responsibility to provide a container or outlet for drainage.

Caster Or Leg Installation

⚠ DANGER

Legs or casters must be installed and the legs or casters must be screwed in completely to prevent bending. When casters are installed the mass of this unit will allow it to move uncontrolled on an inclined surface. These units must be tethered/secured to comply with all applicable codes.

⚠ Warning

The unit must be installed in a stable condition with the front wheels locked. Locking the front casters after installation is the owner’s and operator’s responsibility.

⚠ Warning

Use a jack to lift the refrigeration unit off the ground just far enough to remove the leg/caster. Place blocking underneath the unit. Do not work underneath a raised unit without proper blocking. Do not lift the unit more than necessary to remove the leg/caster. Lifting the unit too far can make the unit unstable.

⚠ Caution

All single-section units require that the swivel casters be mounted on the front and rigid casters be mounted on the rear.

1. Carefully place the unit on its back.
2. Located at each caster mounting location are 4 Phillips head screws, for a total of 16 screws. Remove them.
3. Place a locking plate caster or leg over one of the front holes, matching the 4 mounting holes to the pre-drilled holes in the underside of the unit. Insert 4 Phillips head screws and tighten. Repeat with the other locking front caster or leg.

4. Repeat step 3 with the non-locking casters or legs in the rear of the unit.
5. Carefully lift the unit upright.

⚠ Caution

After installing casters, the unit must stand upright for twenty-four (24) hours before being powered up to assure oil return to the compressor sump.

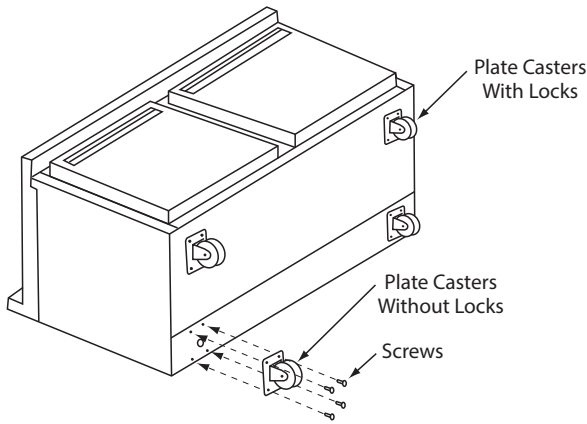

LEG LEVELING

All four legs are adjustable. Adjust each leg until the unit is stable and level left to right. If necessary adjusting the front legs slightly higher than the rear by about 1/8" (3mm) will help the door remain closed.

CASTER AND LEG MOUNTING DETAIL

A universal bolt hole pattern is provided on the bottom of the cabinet. It will accommodate any leg or caster. Simply line up the plate holes with the corresponding cabinet holes.

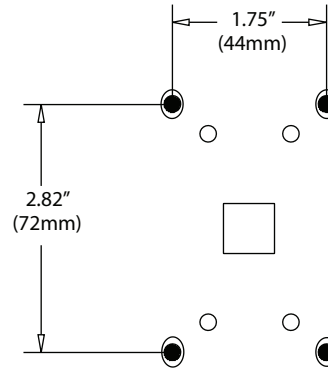

NOTE: If hole pattern on caster/leg matches the one above mount in middle set of holes.

- 3" Caster - 3234024
- 5" Caster - 3234161
- 6" Leg - 3234791

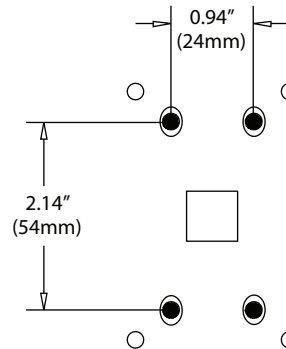

NOTE: If hole pattern on caster/leg matches the one above mount in inner set of holes.

- 2" Caster - 3234148

Loosen Freezer Compressor Bolts

Semi hermetic models should be loosened before operating. Loosen (but do not remove) the bolts on the compressor. If not done the freezer may vibrate excessively when the compressor is running.

THIS PAGE INTENTIONALLY LEFT BLANK

Section 3 Operation

DANGER

The on-site supervisor is responsible for ensuring that operators are made aware of the inherent dangers of operating this equipment.

DANGER

Do not operate any appliance with a damaged cord or plug. All repairs must be performed by a qualified service company.

DANGER

Never stand on the unit! They are not designed to hold the weight of an adult, and may collapse or tip if misused in this manner.

Warning

Do not contact moving parts.

Warning

All covers and access panels must be in place and properly secured, before operating this equipment.

Warning

The operator of this equipment is solely responsible for ensuring safe holding temperature levels for all food items. Failure to do so could result in unsafe food products for customers.

Warning

Overloading shelves can damage equipment or cause bodily injury.

Warning

Damp or wet hands may stick to cold surfaces.

Warning

Do not block the supply and return air grills or the air space around the air grills. Keep plastic wrappings, paper, labels, etc. from being airborne and lodging in the grills. Failure to keep the air grills clear will result in unsatisfactory operation of the system.

Caution

Do not throw items into the storage area. Failure to heed this recommendation could result in damage to the interior of the cabinet or to the blower coil.

CAREL CONTROL - STANDARD



Location

The Carel temperature control is mounted in a junction box on the back of the unit that includes the thermistors and power cord.

Start-up

At initial start-up or anytime power is disconnected and then reconnected to the unit, the control will start the unit in defrost.

Defrost

Defrost can be terminated and initiated by pressing the snowflake button. Display freezes the last cabinet temperature recorded until defrost is completed and the cabinet reaches set point again.

The unit can be turned on and off by pressing the on/off button on the control.

Set Point Adjustment

To adjust the set-point temperature, press and hold the set button until the current set point appears and is blinking on the screen. Press the down or up arrows to adjust to the desired temperature. Press the set button again to save the temperature.

Factory set point:

407p Freezer	-1.5°F
406p/4048 Cooler	33°F

Error Codes

LED Flashes: This means there is a function that is being delayed by a timer/external signal or disabled by another process that is already going on. For example, the compressor icon will flash if the cabinet temperature is above the cut-in temperature, but the control hasn't met the minimum compressor off-time.

E0: Air probe error

E1: Coil probe error

LO: Low temperature alarm (-20°F for 90 minutes)

HI: High temperature alarm (+20°F for 90 minutes)

Ef: Unit operating on parameter error

Ed: Defrost ended on timeout rather than by temperature

Controls/Programming/Settings

R290 REFRIGERATORS

The control will initiate a defrost at start up. This defrost will continue up to 41°F or a minimum runtime of 1 minute/ maximum runtime of 75 minutes. The evaporator fans will run continually during the operation of the unit. There will be no drip time after the defrost. The compressor powers on immediately after reaching defrost termination temp.

When the control calls for cooling, a minimum compressor on time is 2 minutes. Condensing unit/evaporator fans power on and the normal cooling cycle continues.

Defrost will initiate after 6 hours of actual time (note: this is not running time). Display freezes the last cabinet temp recorded until defrost is completed and the cabinet reaches set point again.

FREEZERS

Plug the unit in to begin operation. At initial start-up or anytime power is disconnected, then reconnected to the unit, the control will start the unit in defrost.

The unit can be turned on and off by pressing the on/off button on control. The unit will begin in a defrost cycle if it is turned on at the control.

After initializing, the control will immediately enter a DEFROST mode. The compressor and condenser fan as well as the evaporator fan will remain off until initial defrost is complete. This initial defrost cycle may take up to 15 minutes to complete, then the freezing cycle will begin.

After initializing and the defrost cycle, the electronic temperature control will cycle the compressor, evaporator fan motor, and condenser fan motor to maintain box temperature at the control setting.

With the doors closed, the temperature of the cabinet should reach 0°F (-18°C) on freezers in about one hour after the freezing cycle begins. The electronic temperature control constantly monitors box temperature as well as evaporator coil temperature to maintain consistent product temperatures. As an added energy-saving feature, the electronic controller will switch the evaporator fan motor on and off with the compressor and condenser fan motor.

During normal operation the evaporator fan may cycle and/or pulse independently of the compressor. Consult the service manual or contact Technical Support at 1-844-724-CARE if you are unsure of the proper function.

Electronic Temperature Control Location & Adjustment

The control is located in the control box at the rear of the unit. It is factory set at mid-range to maintain about -3°F

(-18°C) box temperature. To adjust for colder temperatures, press and hold the set button until the current set point appears and is blinking on the screen. Press the down arrow to adjust to the desired temperature. Press the set button to save the temperature.

To adjust for warmer temperatures, press and hold the set button until the current set point appears and is blinking on the screen. Press the up arrow to adjust to the desired temperature. Press the set button to save the temperature

Freezer Automatic Defrost

The control is set to defrost every 5 hours. The maximum defrost duration is 35 minutes.

Freezer Manual Defrost

If a manual defrost is desired, simply unplug the unit for several seconds, then plug unit back in. This will cause the control to re-initialize and then enter a defrost cycle. The unit can also be put into a manual defrost by pressing and holding the snowflake button on the control.

When the control enters the defrost mode, whether manual or automatic, it switches on the compressor and condenser fan motor, and energizes the hot gas solenoid to warm the evaporator coil and melt all frost accumulated during the previous refrigeration cycle. The control will continue the defrost cycle for a MAXIMUM of 35 minutes depending on the amount of frost accumulated on the evaporator coil.

After the defrost cycle is complete, the control returns to a normal refrigeration cycle, however the evaporator fan motor will not switch on for two minutes AFTER the compressor and condenser fan motor have begun operating.

EVAPORATOR FAN OPERATION

	Cooling Cycle		Defrost Cycle
	Compressor On	Compressor Off	Compressor Off Refrig. / On Freezer
	Evap Fan	Evap Fan	Evap Fan
R290 Refrigerators	On	On	On
R290 Freezer	On	Off	Off

DANFOSS CONTROL - EXPORT

R290 Freezer

Freezers are factory set at mid-range to maintain about -3°F (-19°C) box temperature.

1. At initial start-up or anytime power is disconnected, then reconnected to the unit, the control will go into defrost mode
2. The control will enter a DEFROST mode and the display will read dEF. The compressor and condenser fan as well as the evaporator fan will remain off until this initial defrost is complete. This initial defrost cycle may take up to 35 minutes to complete.
3. The display will continue to read dEF for an additional 30 minutes while the freezing cycle cools the box to the set temperature.
4. Then the thermostat will display box temperature.
5. The temperature control will cycle the compressor, evaporator fan motor and condenser fan motor to maintain box temperature at the control setting. For more information see R290 Evaporator Fan Operation on page 16.

R290 Freezer Automatic Defrost

The control also monitors compressor total running time and will enter a defrost cycle after total compressor running time is greater than seven hours since the last defrost cycle OR if evaporator coil temperature drops below -23°F (-31°C) (indicating excessive frost on the coil).

R290 Freezer Manual Defrost

If a manual defrost is desired, hold the upper left button for five seconds or unplug the unit for several seconds, then plug unit back in. This will cause the control to re-initialize and then enter a defrost cycle.

When the control enters the defrost mode, it switches off the evaporator fan motor, compressor and condenser fan motor, and switches on the defrost heater to warm the evaporator coil. Thereby melting all frost accumulated during the previous refrigeration cycle. The digital temperature display will now read dEF. The control will continue the defrost cycle for a MINIMUM of six minutes and a MAXIMUM of 35 minutes depending on the amount of frost accumulated on the evaporator coil.

After the defrost cycle is complete, the control returns to a normal refrigeration cycle, however the evaporator fan motor will not switch on until the evaporator reaches -5°F (-21°C) or two minutes AFTER the compressor and condenser fan motor have begun operating. The digital temperature display will continue to read dEF until the evaporator has returned to normal freezing temperatures (up to 30 minutes).

R290 TEMPERATURE CONTROL & DISPLAY



Operation / Indication			
Status	Displayed	🔊	Comments
Normal (°C)	Temp. [°C]		Unit depends on setting (parameters in control)
Normal (°F)	Temp. [°F]		
Show set-point	Temp.		
Set to Defrost	dEF / Temp		Depends on setting (parameters in control or as chosen by upper left button)
Sensor 1 defect	E01 🚨	X	Air sensor
Sensor 2 defect	E02 🚨	X	Coil sensor
Sensor 3 defect	E03 🚨	X	Open
Sensor 4 defect	E04 🚨	X	Open
High temperature alarm	Hi 🚨	X	Automatically switching at 2 sec rate
Low temperature alarm	Lo 🚨	X	
Line voltage too high, above 140 volts	uHi 🚨	X	
Line voltage too low, below 96 volts	uLi 🚨	X	
Control calls for cooling for more than 24 hours straight	LEA 🚨	X	Time includes defrost. Error will go away if the control cycles off the compressor or if the power is shut off. If error is on a cold pan it could be related to a high ambient temperature or not shutting the rail off nightly.

🚨 All alarms sound for approximately 10 seconds and then are silent for 50 seconds. It will do that for 15 cycles and then remain silent. The alarm code will still be present on the display until the fault clears.

Press upper or lower right button.

- Display show actual set-point (blinking).
 - If buttons untouched for 3 seconds returns to normal.
- Increase set-point by pressing upper button. Max value depends on parameters in control.

- Decrease set-point by pressing lower button. Min value depends on parameters in control.
 - If buttons untouched for 3 seconds returns to normal and stores new set-point.

Press upper left button for 5 seconds.

- Start defrost.

Press lower left button for 5 seconds.

- Unit goes into stand-by mode.
 - The display will read off, then a period.
- Press the lower left button again for 5 seconds.
 - The display will read on.
 - The unit will then start up in the defrost mode, and display will read dEF.

R290 Temperature Alarm

The alarm will sound and flash “HI” or “LO” 90 minutes after the unit has reached its alarm temperature point or after any power interruption if the temperature is above or below the alarm set points. Refrigerators are factory set at mid-range to maintain about 38°F (3°C) box temperature. The high refrigerator temperature point is 50°F (10°C). The low refrigerator temperature point is 25°F (-4°C). Freezers are factory set at mid-range to maintain about -3°F (-19°C) box temperature. The high freezer temperature point is 20°F (-7°C). Freezers do not have a low temperature point.

R290 EVAPORATOR FAN OPERATION

Depending on the units requirements, units may have evaporator fans that run continually or cycle on and off when power is applied. If you have a unit that you notice the fan is cycling, please see the operations sequence below.

During normal operation the evaporator fan may cycle and/or pulse independently of the compressor. Consult Technical Support at 1-844-724-CARE if you are unsure of the proper function.

	Cooling Cycle				Defrost Cycle	
	Compressor On		Compressor Off		Compressor Off	
	Evap Fan On	Evap Fan Off	Evap Fan On	Evap Fan Off	Evap Fan On	Evap Fan Off
Refrigerator	X		Cycles On 2-Min, Off 2-Min		X	
Freezer	X			X		X

CHANGING DISPLAY FROM FAHRENHEIT TO CELSIUS ON ERC112 CONTROL

1. Simultaneously hold the up and down arrows for 5 seconds to access menu for password protected parameters.



2. Screen should temporarily flash **PAS** and then move to a numeric screen.



3. Scroll to **187** using the up/down arrows and push the stand-by button (lower left button) to enter.



4. Scroll to **dis** using the up/down arrows and push the stand-by button (lower left button) to enter into the display menu.



5. Scroll to **CFu** using the up/down arrows and push the stand-by button (lower left button) to enter the display unit menu.



6. **-F** should be displayed indicating Fahrenheit. Use the down arrow to change it to **-C** for Celsius and hit the stand-by button (lower left button) to enter the change.



7. Push the defrost button (upper left button) to move out of the display unit menu.



8. Push the defrost button (upper left button) to move out of the display menu and back to the normal display.

NOTE: For steps 7 and 8, display will return back to normal display after 30 seconds of inactivity.



Section 4 Maintenance

⚠ DANGER

It is the responsibility of the equipment owner to perform a Personal Protective Equipment Hazard Assessment to ensure adequate protection during maintenance procedures.

⚠ DANGER

Failure to disconnect the power at the main power supply disconnect could result in serious injury or death. The power switch DOES NOT disconnect all incoming power.

⚠ DANGER

Disconnect electric power at the main power disconnect for all equipment being serviced. Observe correct polarity of incoming line voltage. Incorrect polarity can lead to erratic operation.

⚠ Warning

Never use sharp objects or tools to remove ice or frost. Do not use mechanical devices or other means to accelerate the defrosting process.

⚠ Warning

When using cleaning fluids or chemicals, rubber gloves and eye protection (and/or face shield) must be worn.

⚠ Warning

When cleaning interior and exterior of unit, care should be taken to avoid the front power switch and the rear power cord. Keep water and/or cleaning solutions away from these parts.

⚠ Warning

Never use a high-pressure water jet for cleaning or hose down or flood interior or exterior of units with water. Do not use power cleaning equipment, steel wool, scrapers or wire brushes on stainless steel or painted surfaces.

⚠ Caution

Maintenance and servicing work other than cleaning as described in this manual must be done by an authorized service personnel.

⚠ Caution

Over shelves and other items mounted to the top of the counters should never be installed in the field due to the potential damage to the refrigeration system.

Responsibility

You are responsible for maintaining the equipment in accordance with the instructions in this manual. Maintenance procedures are not covered by the warranty.

Maintenance	Daily	Weekly	Monthly	After Prolonged Shutdown	At Start-Up
Interior	X			X	X
Gasket	X		X	X	X
Exterior	X			X	X
Drain		X		X	X
Condenser Coil			X	X	X
Casters			X	X	X

Interior Cleaning

The interior can be cleaned using soap and warm water. If this isn't sufficient, try ammonia and water or a nonabrasive liquid cleaner.

PREVENTING BLOWER COIL CORROSION

To help prevent corrosion of the blower coil, store all acidic items, such as pickles and tomatoes, in seal-able containers. Immediately wipe up all spills.

Exterior Cleaning

⚠ Caution

Never use an acid based cleaning solution on exterior panels! Many food products have an acidic content, which can deteriorate the finish. Be sure to clean the stainless steel surfaces of ALL food products.

Clean the area around the unit as often as necessary to maintain cleanliness and efficient operation.

Wipe gasket and surfaces with a damp cloth rinsed in water to remove dust and dirt from the outside of the unit. Always rub with the "grain" of the stainless steel to avoid marring the finish. If a greasy residue persists, use a damp cloth rinsed in a mild dish soap and water solution. Wipe dry with a clean, soft cloth.

Never use steel wool or abrasive pads for cleaning. Never use chlorinated, citrus based or abrasive cleaners.

Stainless steel exterior panels have a clear coating that is stain resistant and easy to clean. Products containing abrasives will damage the coating and scratch the panels. Daily cleaning may be followed by an application of stainless steel cleaner which will eliminate water spotting and fingerprints. Early signs of stainless steel breakdown are small pits and cracks. If this has begun, clean thoroughly and start to apply stainless steel cleaners in attempt to restore the steel.

Wipe casters with a damp cloth monthly to prevent corrosion.

DRAIN

Each unit has a drain located inside the unit that removes the condensation from the evaporator coil and routes it to an external condensate evaporator pan. Each drain can become loose or disconnected during normal use. If you notice water accumulation on the inside of the unit, be sure the drain tube is connected to the evaporator drain pan. If water is collecting underneath the unit, make sure the end of the drain tube is in the condensate evaporator. The leveling of the unit is important as the units are designed to drain properly when level. Be sure all drain lines are free of obstructions.

Cleaning the Condenser Coil

In order to maintain proper refrigeration performance, the condenser fins must be cleaned of dust, dirt and grease regularly. It is recommended that this be done monthly. If conditions are such that the condenser is totally blocked in a month, the frequency of cleaning should be increased. Clean the condenser with a vacuum cleaner or stiff brush. If extremely dirty, a commercially available condenser cleaner may be required.

Failure to maintain a clean condenser coil can initially cause high temperatures and excessive run times. Continuous operation with a dirty or clogged condenser coil can result in compressor failure. Neglecting the condenser coil cleaning procedures will void any warranties associated with the compressor and cost to replace the compressor.

Doors/Hinges

Over time and with heavy-use doors, the hinges may become loose. If this happens, tighten the screws that mount the hinge brackets to the frame of the unit. Loose or sagging doors can cause the hinges to pull out of the frame, which may damage both the doors and the hinges. In some cases this may require qualified service agents or maintenance personnel to perform repairs.

Door Adjustment

If the door needs lowering at the handle, use a 5/16" (8mm) wrench to loosen the hinge screws and install a spacer outside of the hinge. Tighten the screws.

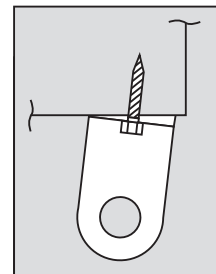

If the door needs to be higher at the handle, use a 5/16" (8mm) wrench to loosen the hinge screws and install a spacer inside of the hinge. Tighten the screws.

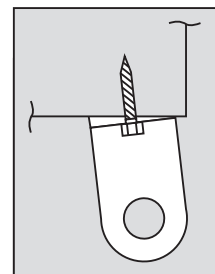

Section 5 Troubleshooting

Problem -> Cause -> Correction Chart

Problem	Cause	Correction
Cabinet not running	Fuse blown or circuit breaker tripped.	Replace fuse or reset circuit breaker.
	Power cord unplugged.	Plug in power cord.
	Thermostat set too high.	Set thermostat to lower temperature.
	Main power switch turned off.	Turn main power switch on.
	Cabinet in defrost cycle. (Freezer models)	Wait for defrost cycle to finish.
Condensing unit runs for long periods or continuously	Excessive amount of warm product placed in cabinet.	Allow adequate time for product to cool down.
	Prolonged door openings or door(s) ajar.	Make sure door(s) are closed when not in use. Avoid prolonged door openings.
	Door gasket(s) not sealing properly.	Check gasket condition. Adjust door or replace gasket if necessary.
	Dirty condenser coil.	Clean the condenser coil.
	Evaporator coil iced over.	Turn unit off and allow coil to defrost. Make sure thermostat is not set too cold. Also, check gasket condition.
Cabinet temperature is too high	Thermostat set too high.	Set thermostat to lower temperature.
	Poor air circulation in cabinet.	Re-arrange product to allow proper air circulation.
	Exterior thermometer is out of calibration.	Re-calibrate thermometer.
	Excessive amount of warm product placed in cabinet.	Allow adequate time for product to cool down.
	Prolonged door openings or door(s) ajar.	Make sure door(s) are closed when not in use. Avoid prolonged door openings.
	Dirty condenser coil.	Clean the condenser coil.
	Evaporator coil iced over.	Turn unit off and allow coil to defrost. Make sure thermostat is not set too cold. Also, check gasket condition.
Cabinet is noisy	Loose part(s).	Locate and tighten loose part(s).
Refrigerator is freezing product	Thermostat is set too low.	Set thermostat to higher temperature.
	Dirty condenser coil.	Clean the condenser coil.
	Not enough cabinet clearance for proper refrigeration system operation.	Move cabinet or make other adjustments to gain proper cabinet clearances.
Compressor will not start	Low voltage to cabinet.	Check and correct incoming voltage to cabinet.

406P and 4048P Wiring Diagram

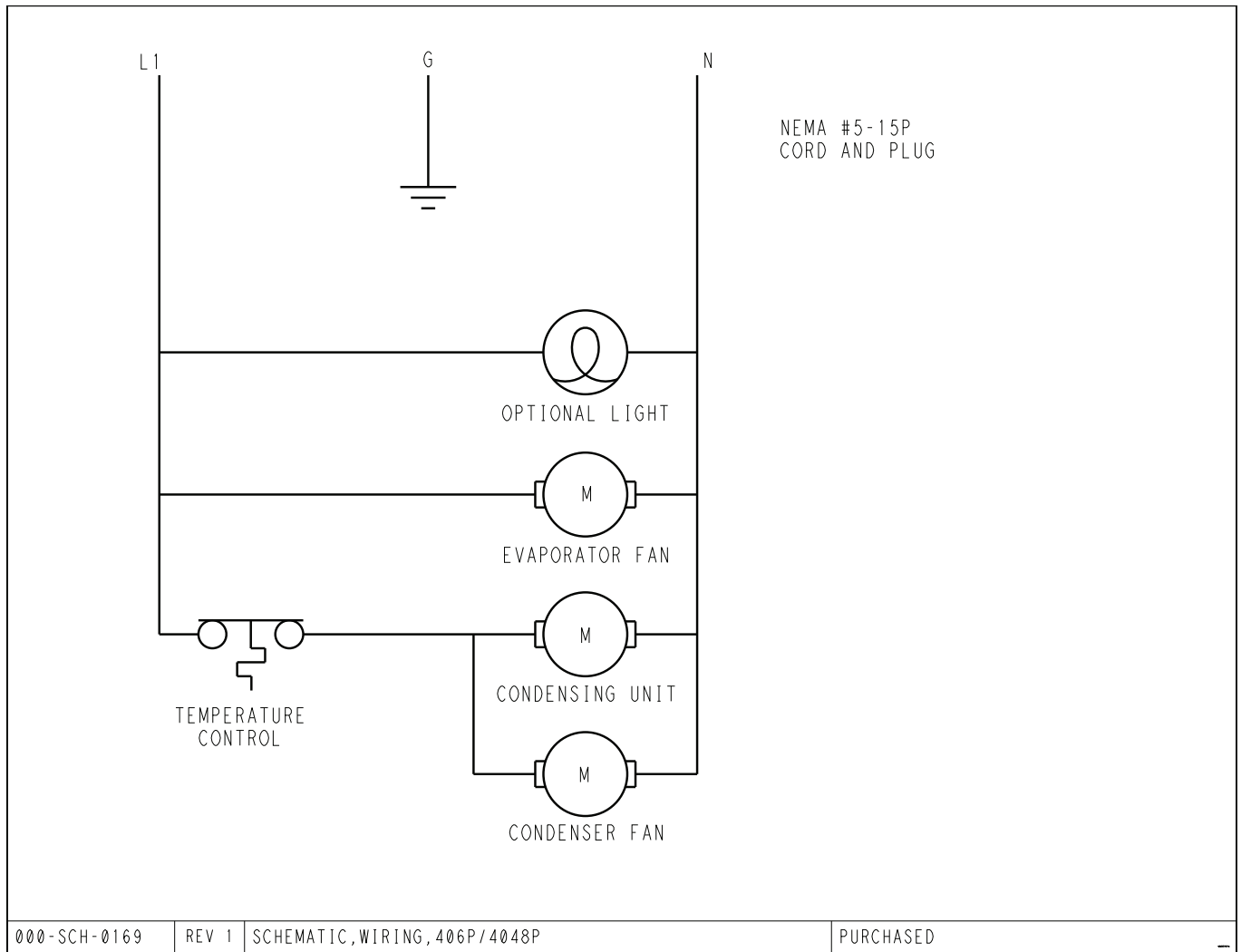

407P Wiring Diagram

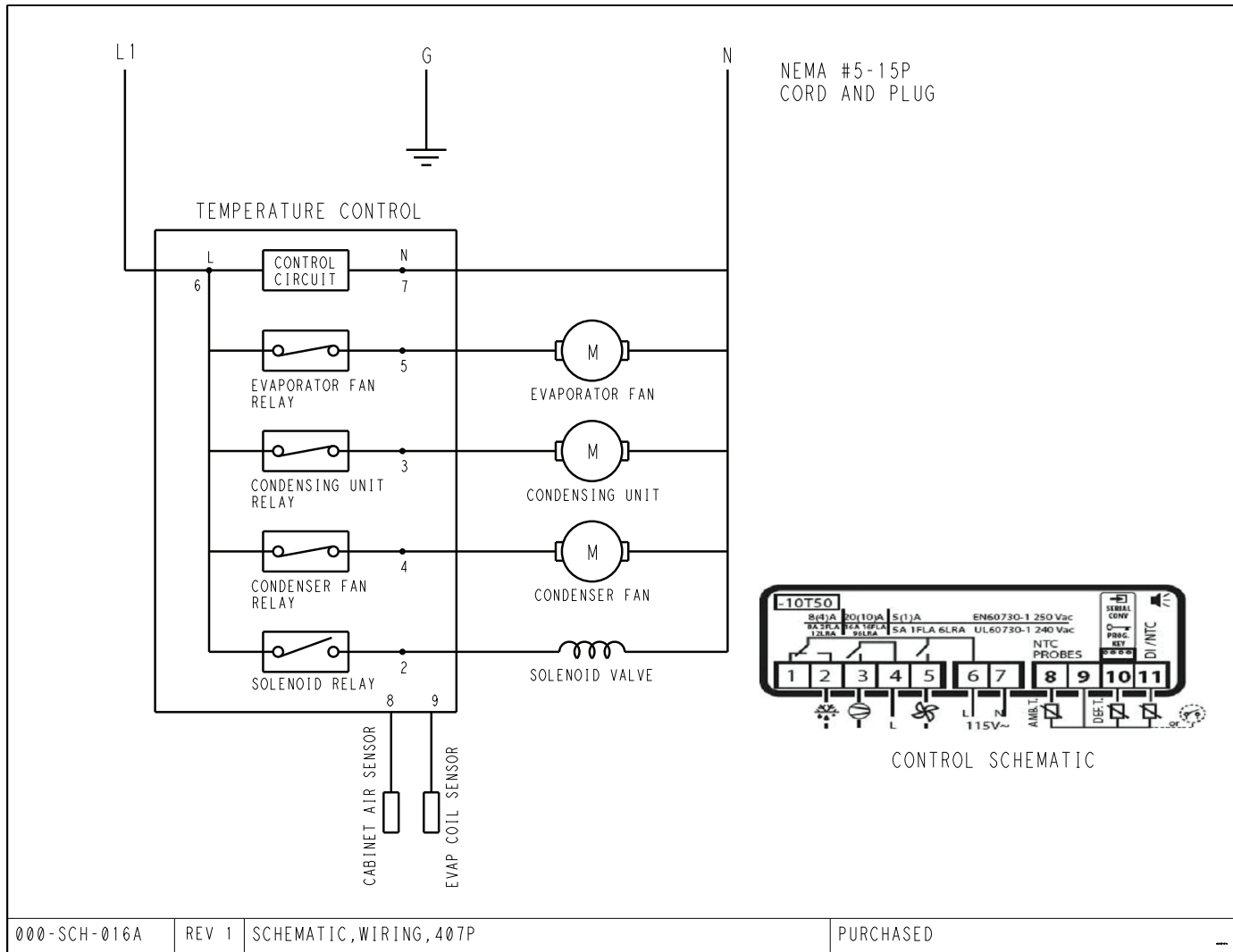

407P-CE Wiring Diagram

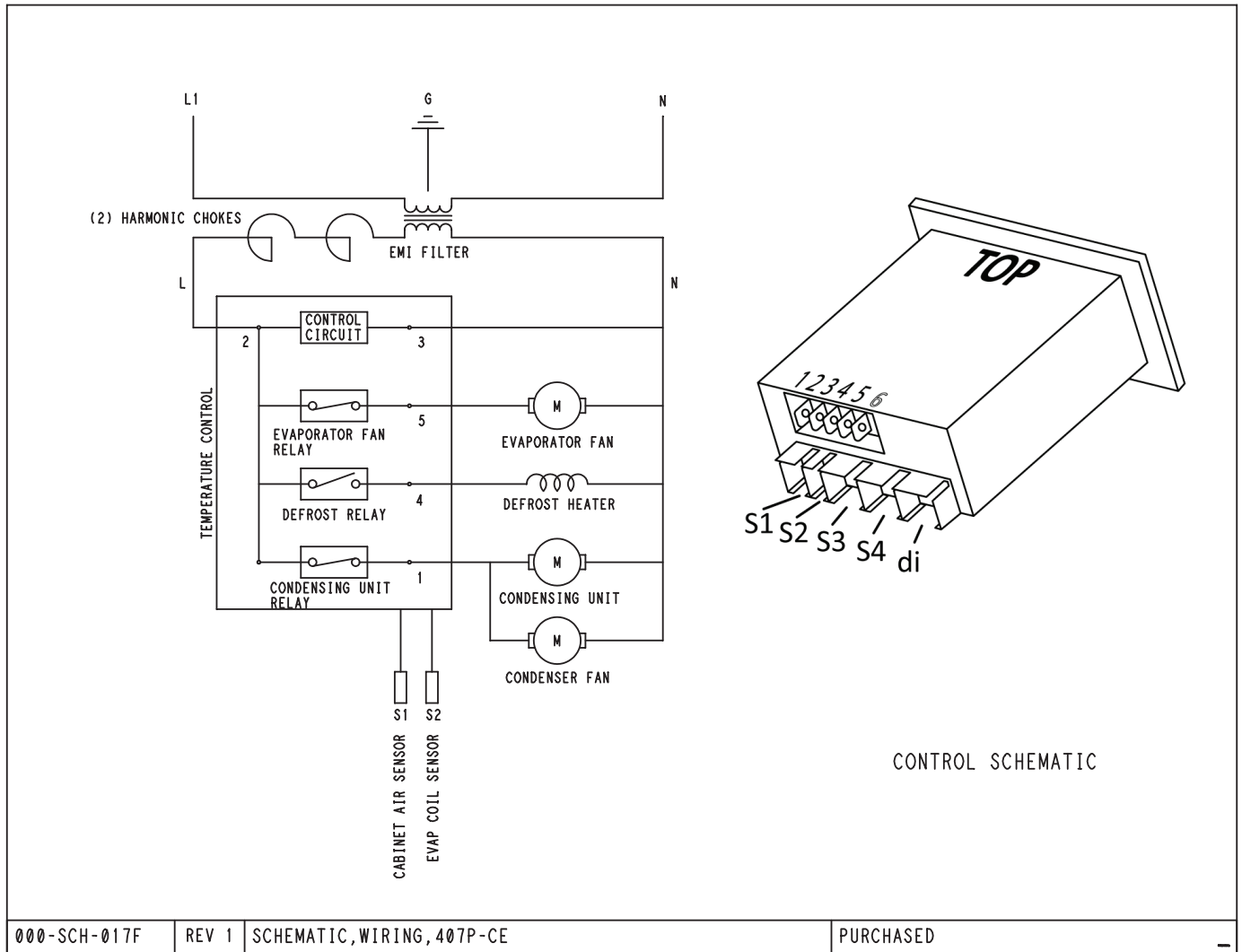

Import: Germany Welbilt Deutschland Auf der Weih 11 35745 Herborn Germany +49 2772 58050	Import: United Kingdom Welbilt UK Limited Provincial Park, Nether Lane Ecclesfield Sheffield, S35 9ZX United Kingdom +44 1483 464900
---	--



Welbilt offers fully-integrated kitchen systems and our products are backed by KitchenCare® aftermarket parts and service. Welbilt's portfolio of award-winning brands includes **Cleveland™**, **Convotherm®**, **Crem®**, **Delfield®**, **fitkitchen®**, **Frymaster®**, **Garland®**, **Kolpak®**, **Lincoln®**, **Manitowoc®**, **Merco®**, **Merrychef®** and **Multiplex®**.

Bringing innovation to the table • welbilt.com