



INSTRUCTIONS FOR USE

5-10 US TRAYS BLAST CHILLER

Serie "NEW RUNNER"
EVX-205 Control panel version

BCB/05US
BCB/10US

Manual BCB US Rev00 01-2019



www.gemm-srl.com

Serial Number

A large, empty rectangular box with a thin black border, intended for the user to enter a serial number. The box is vertically oriented and occupies most of the page's width and height.

INDEX

1. SAFETY **6**

- 1.1 – Symbols used
- 1.2 – General warnings
- 1.3 – Residual risks
- 1.4 – Personnel
- 1.5 – Improper use
- 1.6 – Safety devices
- 1.7 – Stop functions

2. GENERAL INFORMATION **11**

- 2.1 – Marking
- 2.2 – Declaration of conformity
- 2.3 – Warranty
- 2.4 – After-sales service
- 2.5 – How to use and keep the manual

3. MACHINE DESCRIPTION **14**

- 3.1 – Technical data
- 3.2 – Description of blast chiller and its use
 - 3.2.1 – Main parts
- 3.3 – Noise
- 3.4 – Ambient conditions

4. TRANSPORT AND HANDLING **18**

- 4.1 – Transport
- 4.2 – Handling the packed blast chiller
 - 4.2.1 – Weight and dimensions
 - 4.2.2 – Means required

-
- 5.1 – Preparation for installation
 - 5.2 – Unpacking
 - 5.2.1 – Means required
 - 5.2.2 – Unpacking procedure
 - 5.3 – Handling the blast chiller
 - 5.3.1 – Means required
 - 5.3.2 – Handling the unpacked blast chiller
 - 5.4 – Blast chiller assembly

-
- 6.1 – Connections
 - 6.1.1 – Electrical connection
 - 6.2 – Preliminary checks
 - 6.2.1 – Regulation

-
- 7.1 – Recommended use
 - 7.2 – Non recommended use
 - 7.3 – Control panel
 - 7.4 – Control procedures
 - 7.5 – Product recommended use

 - 7.6 – **Soft chilling**
 - 7.6.1 – Setting and Selecting of soft chilling cycle (Soft blast chilling)

 - 7.7 – **Hard chilling**
 - 7.7.1 – Setting and Selecting of hard chilling cycle (Hard blast chilling)

 - 7.8 – **Freezing**
 - 7.8.1 – Setting and Selecting a of freezing cycle

 - 7.9 – Special functions and uses
 - 7.9.1 – Pre-chilling function
 - 7.9.2 – Defrost
 - 7.9.3 – Long idle perdios

8. MAINTENANCE **32**

- 8.1 – Special precautions
- 8.2 – Routine maintenance
 - 8.2.1 – Routine maintenance table (tab. 5)
 - 8.2.2 – Cleaning the chamber
 - 8.2.3 – Cleaning the outside of the appliance
 - 8.2.4 – Cleaning the condenser
 - 8.2.5 – Cleaning the core probe
- 8.3 – Extraordinary maintenance
- 8.4 – Operating anomalies and faults
 - 8.4.1 – Alarms
 - 8.4.2 – Errors

9. DISMANTLING **38**

10. DISPOSAL **38**

- 10.1 – Disposal method

11. SPARE PARTS **39**

- 11.1 – Ordering spare parts

12. APPENDICES **39**

1. – SAFETY

1.1 – SYMBOLS USED



This symbol indicates information and warnings which if not observed could damage the appliance or compromise the safety of personnel.



This symbol indicates information and warnings regarding electrical devices which if not observed could damage the appliance or compromise the safety of personnel.



To identify any terminal which is intended for connection to an external conductor for protection against electric shock in case of a fault, or the terminal of a protective earth (ground) electrode.



To identify the terminals which, when connected together, bring the various parts of an equipment or of a system to the same potential, not necessarily being the earth (ground) potential, e.g. for local bonding.

1.2 – GENERAL WARNINGS



IMPORTANT: before using the appliance read this manual carefully and follow the technical operating instructions and indications to the letter. The operator must know the position and function of all the control devices and the characteristics of the blast chiller.



The blast chiller complies with current safety regulations, but improper use may cause damage to persons and things.



At the time of installation all operatives must be suitably trained in accident hazards, operator safety devices, general accident prevention regulations described in international directives and the current law in the countries where the appliance is used. Start-up and use of the appliance must be exclusively in the hands of trained personnel. The behaviour of operators must in any case scrupulously observe accident prevention regulations in the country where the appliance is used.



Do not remove or deface the plates fitted to the appliance by the manufacturer.



The blast chiller must not be used if the control panel or any other part is damaged.



Do not obstruct the front and/or rear air vents on the appliance; do not place food to be processed up against the ventilation grilles or air ducts, or directly on the bottom of the chamber.



Promptly report any anomalies in operation.



Use only accessories recommended by the manufacturer.



Do not store explosive substances such as aerosol cans with a flammable propellant inside the appliance.



Do not expose the appliance to rain or sprays of water.



Routine and extraordinary maintenance that require the electrical box to be opened or even partial dismantling of the blast chiller must be carried out only after the appliance has been disconnected.



If the supply cord is damaged, it must be replaced with an identical one by the manufacturer, its service agent or similarly qualified persons in order to avoid a hazard - risk of electric shock.

The manufacturer has no responsibility in the following cases:

- **the maintenance plan is not carried out;**
- **unauthorized alterations and/or operations;**
- **spare parts used are not original;**
- **failure to observe even part of the contents of this manual;**
- **improper use of the appliance.**

Any tampering with or unauthorized replacement of one or more appliance parts or components and use of accessories and consumables different from the original ones can constitute a hazard and relieve the manufacturer of any civil or penal responsibility.

If in doubt about operation of the appliance, refrain from using it and contact the manufacturer.

1.3 – RESIDUAL RISKS



LOW TEMPERATURE BURN HAZARD

During its operation the appliance runs extremely low temperatures: avoid direct contact with the internal parts immediately after opening the door.

1.4 – PERSONNEL

This manual is for the use of operators, authorized fitters and maintenance engineers.



Operators must not carry out operations reserved for maintenance engineers or specialised technicians.

The manufacturer accepts no responsibility for damage deriving from failure to observe this rule.

- **Appliance operator:** specialised person who can operate the appliance in normal working conditions by using the relevant controls. The operator must also be capable of carrying out simple routine maintenance (cleaning, loading) and starting or resetting the appliance after a power failure.
- **Specialised electrician:** specialised electrician who has been trained by the manufacturer to work on the appliance. The specialised electrician must be capable of installing the appliance and operating it in normal conditions; s/he is qualified to carry out all electrical and mechanical adjustments, maintenance and repairs. S/he is able to operate with live electrical control boxes and connector blocks.
- **Qualified fork-lift operator:** person qualified in handling materials on the company's premises, holder of a licence for the use of fork-lift trucks.

1.5 – IMPROPER USE

The blast chiller must not be used:

- for purposes different from those given in paragraph 3.2 “Description of blast chiller and its use”;
- with safety systems not working;
- after badly done installation;
- by untrained personnel;
- when maintenance has not been carried out, or has been carried out badly;
- when non-original spare parts are used;
- with damaged power lead and/or electrical socket;
- with obstructed air ducts (ref. 1 fig. 1);
- with the food to be processed placed against the ventilation grilles (ref. 1 fig. 1), air ducts, or on the bottom of the chamber (ref. 2 fig. 1).

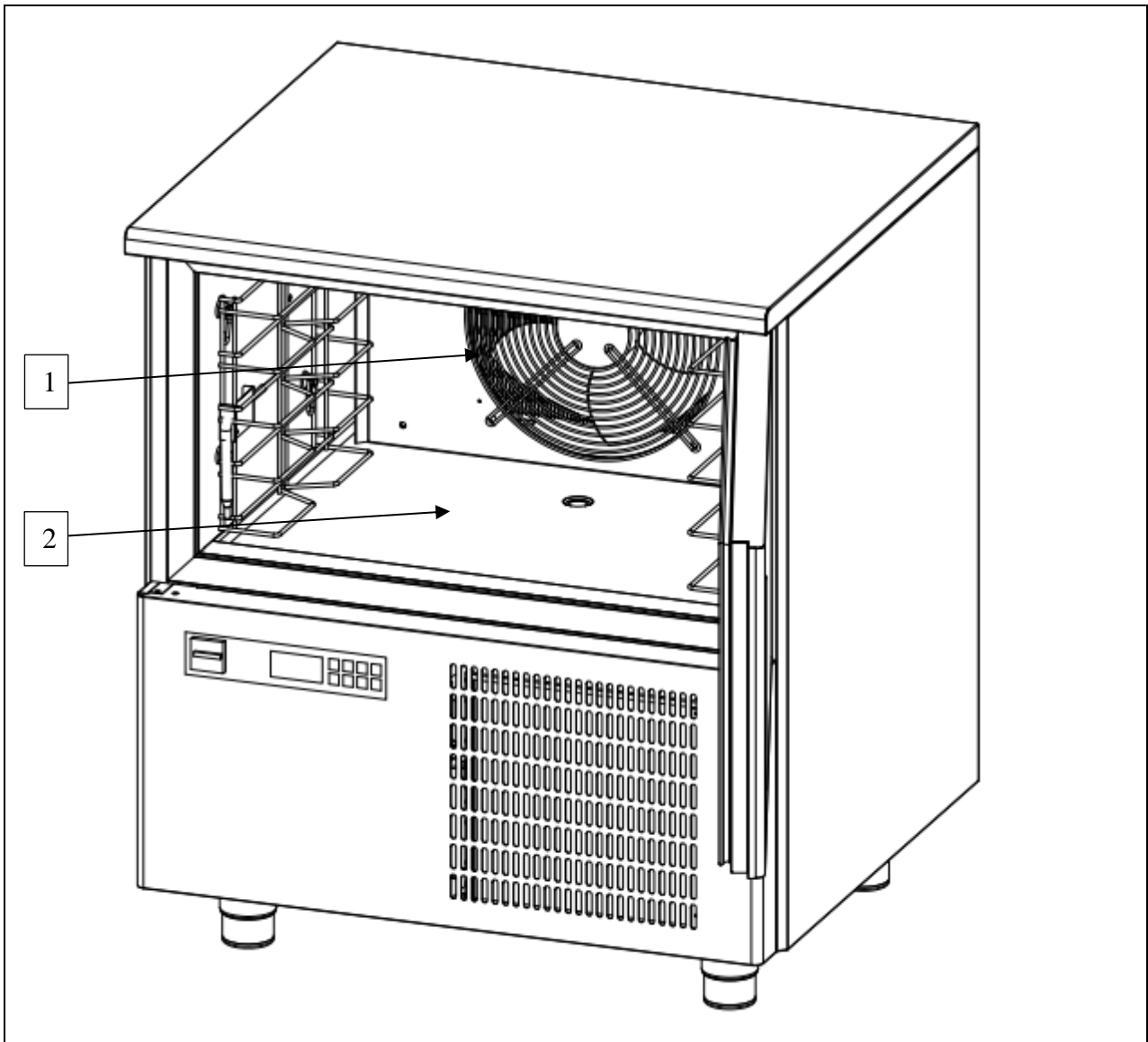

Fig. 1

1.6 – SAFETY DEVICES

Personnel exposed to the hazards inherent in moving parts are protected by special safety devices on the appliance.

- grilles covering the cooling fans (ref. 1 fig. 2);
- grilles covering the condenser unit (ref. 2 fig. 2).

The appliance is also provided with devices to protect the food during processing. Below is a list of the safety devices on the appliance.

- Sensor reads and signals door opening. If the doors remains open for a presetted time, it will appear on the display the message “ **id** ” combined with a acoustic alarm and the compressor will switch off.
- Sensor (ref. 3 fig. 2) located on cooling circuit signals any overheating of the equipment and places the machine on standby.
- Differential magnetothermal overload relay for compressor protection: only in three phase equipment.

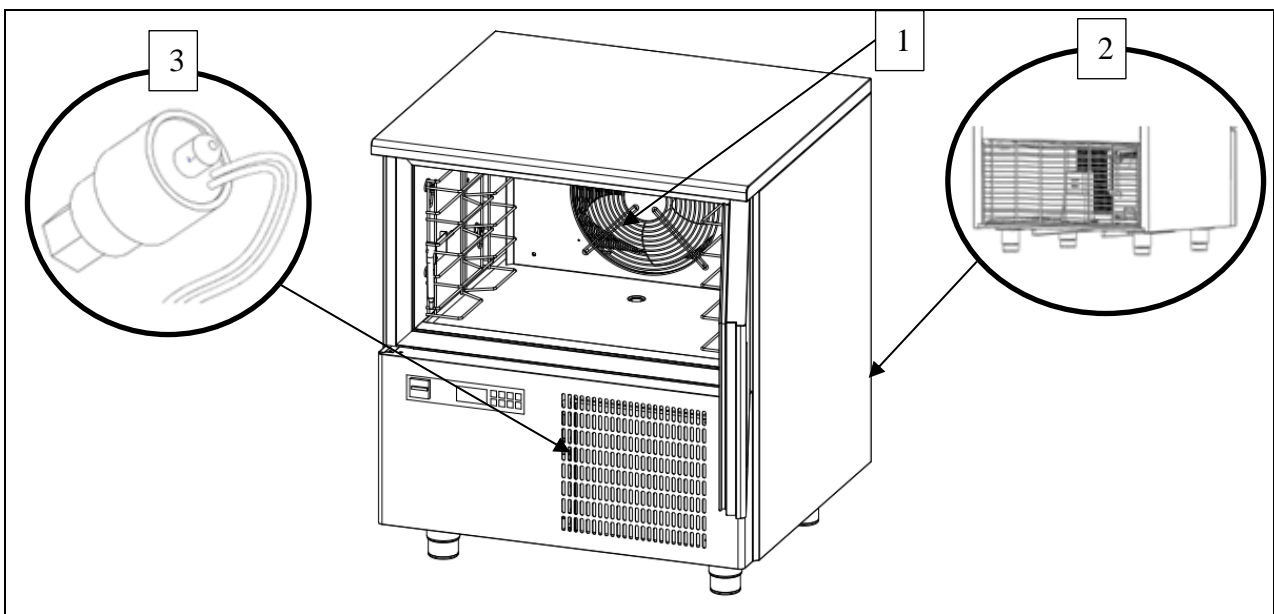



Fig. 2

1.7 – STOP FUNCTIONS

The entire appliance is controlled by an electronic circuit board. The stop function is represented by the  button (ref. 1 fig. 3). Whatever condition the machine is in, holding down the  button for 3 seconds sets in standby the machine. Whatever condition the machine is in, switching off the main switch (ref. 2 fig. 3) cuts out the circuit board.

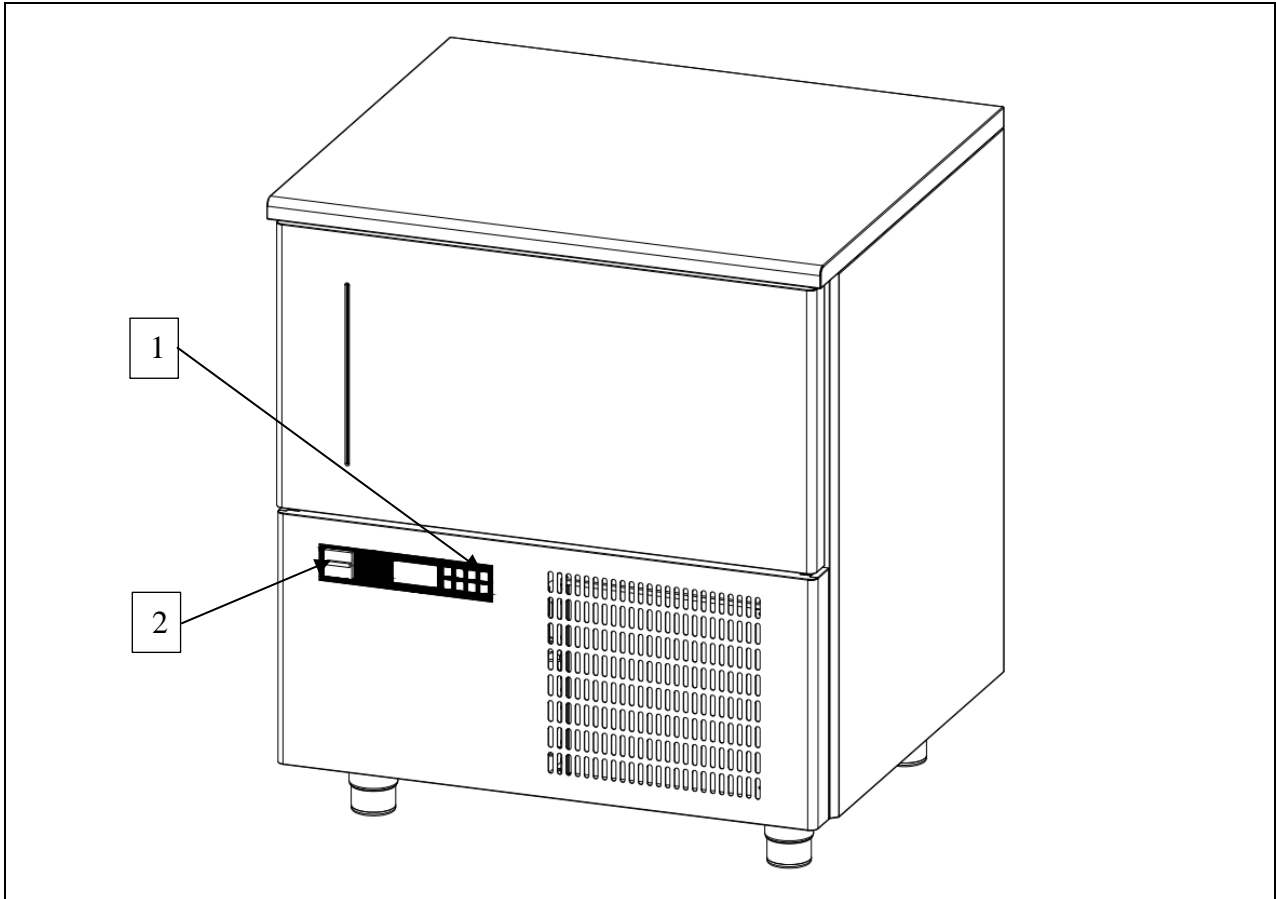

Fig. 3

2 – GENERAL INFORMATION

Thank you for choosing a blast chiller of our production.

Read this manual very carefully and make sure it is available to those who will install, use and maintain the equipment.

2.1 – MARKING

The ID plates are located on the outside of the appliance, in the bottom right-hand corner of the front: Fig. 4 below shows copies.



Fig. 4

2.2 – DECLARATION OF CONFORMITY



DICHIARAZIONE DI CONFORMITA'

DECLARATION OF CONFORMITY

Noi
The following

GEMM S. r. l.
Via Del Lavoro, 37
31013 Codognè (Tv) - Italy
Tel. 0438 778504 Fax 0438 470249

In accordo con la direttiva Macchine 2006/42/CE, la Direttiva 2014/30/UE (Compatibilità Elettromagnetica), Direttiva "RoHS" 2011/65 UE
According to the 2006 /42/EC Machine Directive, the EMC Directive 2014/30/EU, 2011/65 UE "RoHS" directive.

Tipo di apparecchiatura
Type of equipment

Abbatitore di temperatura
Blast chiller / Shock freezer

Nome marchio commerciale
Brand name of trademark

GEMM
GEMM

Tipo, Modello
Type designation

BCB/05US – BCB/10US
BCB/05US – BCB/10US

Matricola
Serial number

Costruttore
Manufacturer

GEMM S. r. l.
GEMM S. r. l.

Le norme armonizzate o le specifiche tecniche (designazioni) che sono state applicate in accordo con le regole della buona arte in materia di sicurezza in vigore nella CEE sono:
The following harmonised standards or technical specifications (designations) which comply with good engineering practice in safety matters in force within the EEC have been applied:

EN 60335 - 1 : 2012 + A11 :2014
EN 60335-2-89:2010 + A1:2016
EN 61000-3-2:2014
EN 61000-3-3:2014
EN 55014-1:2006 + A1 :2009 + A2:2011
EN55014-2:1997 + AC:1997 + A1:2001 + A2:2008

Il prodotto ricade in articolo 4.3 della direttiva 2014/68/UE Attrezzature a Pressione ed è stata sottoposta alla seguente procedura di valutazione di conformità: progettazione e fabbricazione secondo corretta prassi costruttiva.
The product falls under Article 4.3 of the Pressure Equipment Directive 2014/68 / EU and has been subjected to the following conformity assessment procedure: design and manufacture according to good construction practice.

Il prodotto è conforme alla Direttiva 2009/125/CE Ecodesign "ERP" ed al regolamento (UE) 2015/1095.
The product is compliant with Directive 2009/125 / EC Ecodesign "ERP" and Regulation (EU) 2015/1095.

In qualità di costruttore e/o rappresentante autorizzato della Società all'interno della CEE, si dichiara sotto la propria responsabilità che gli apparecchi sono conformi alle esigenze essenziali previste dalle Direttive su menzionate.
As the manufacturer's authorised representative established within EEC, we declare under full responsibility that the equipment follows the provisions of the Directives stated above.

In applicazione a quanto previsto dalle Direttive citate, le apparecchiature sono state dotate di marcatura CE ed è stato predisposto un adeguato fascicolo tecnico presso la nostra sede.
And, pursuant of above-mentioned Directives, the CE mark has been applied to the equipment. Furthermore, adequate technical material has been prepared and is available from our offices.

Data e luogo di emissione
Date and place of issue

23/01/2019, Codognè

Nome e firma di persona autorizzata
Name and signature of authorised person

Gianluca Possamai

GEMM Srl

Via del Lavoro 37 – Loc. Cimavilla – 31013 CODOGNE' (TV) Italy
Tel. 0039 0438 778504 – Fax 0039 0438 470249 – e-mail: info@gemm-srl.com – web: www.gemm-srl.com
C.F. e P.I. 03441880261 – REA TV 272556 – Reg. Impr. TV 03441880261
Registro Prod. AEE-TV IT08020000001108 - Cop. Soc. € 110.000 i.v.

2.3 – WARRANTY

The warranty covering the various parts of the appliance is valid from the date on the relative delivery note and is as described in the sales agreement.

The warranty does not cover damage to the appliance caused by:

- transport and/or handling;
- operator errors;
- lack of the maintenance described in this manual;
- faults and/or breakages that cannot be traced to faulty operation of the appliance;
- maintenance operations carried out by unqualified personnel;
- improper use.

2.4 – AFTER-SALES SERVICE

Please contact the manufacturer directly for any needs regarding use, maintenance or ordering of spare parts, and specify the identification of the appliance given on the ID plate.



2.5 – HOW TO USE AND KEEP THE MANUAL

The purpose of this manual is to provide all the information necessary to ensure proper use of the appliance in complete safety and independence.

The manual is sub-divided into chapters with paragraphs and sub-paragraphs: the contents page is easily consulted to find any aspect of interest.

The material in this document is provided exclusively for the purpose of information and may be altered without notice. Although great attention is paid to drawing up the manual, **the manufacturer is not responsible for damage deriving from errors, omissions or the use made of the information herein.**

Keep this manual and all the documentation in the appendices in good condition, legible and complete in all its parts; keep it close to the equipment in an accessible place known to all operators.

3 – MACHINE DESCRIPTION

3.1 – TECHNICAL DATA

Model		BCB/05US
External dimensions	inches	33 7/8 X 30 3/4 X 37 3/4
Weight	lb	238
Trays	No.	5 (26X18")
Max load for trays	lb	55
Chamber temperature	°F	203 / - 40
Output	lb	57 (+ 149 °F ÷ + 37 °F); 35 (+ 149 °F ÷ 0 °F)
Gas		R404A
Compressor power	Hp	1
Max. absorbed current	A	14
Power supply voltage		Volt 1x115 ~ 60 Hz

Tab. 1/a

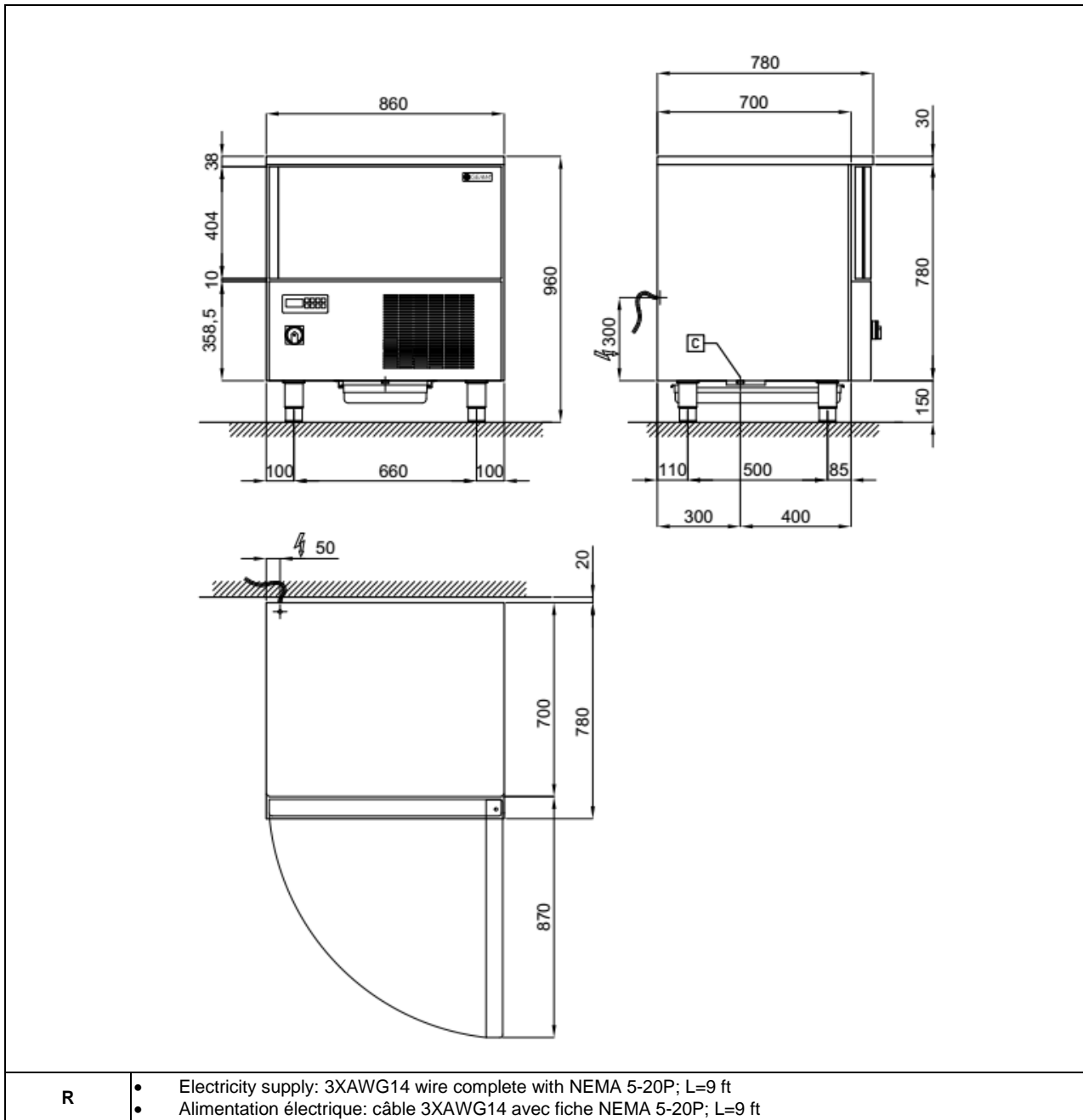

R

- Electricity supply: 3XAWG14 wire complete with NEMA 5-20P; L=9 ft
- Alimentation électrique: câble 3XAWG14 avec fiche NEMA 5-20P; L=9 ft

Fig. 5/a

Model	BCB/10US	
External dimensions	inch	33 7/8 X 33 7/8 X 61 3/8
Weight	lb	348
Trays	No.	10 (26X18")
Max load for trays	lb	55
Chamber temperature	°F	203 / - 40
Output	lb	75 (+ 149 °F ÷ + 37 °F); 48.5 (+ 149 °F ÷ 0 °F)
Gas		R404A
Compressor power	Hp	1 1/2
Max. absorbed current	A	10
Power supply voltage		Volt 1x230 ~ 60 Hz

Tab. 1/b

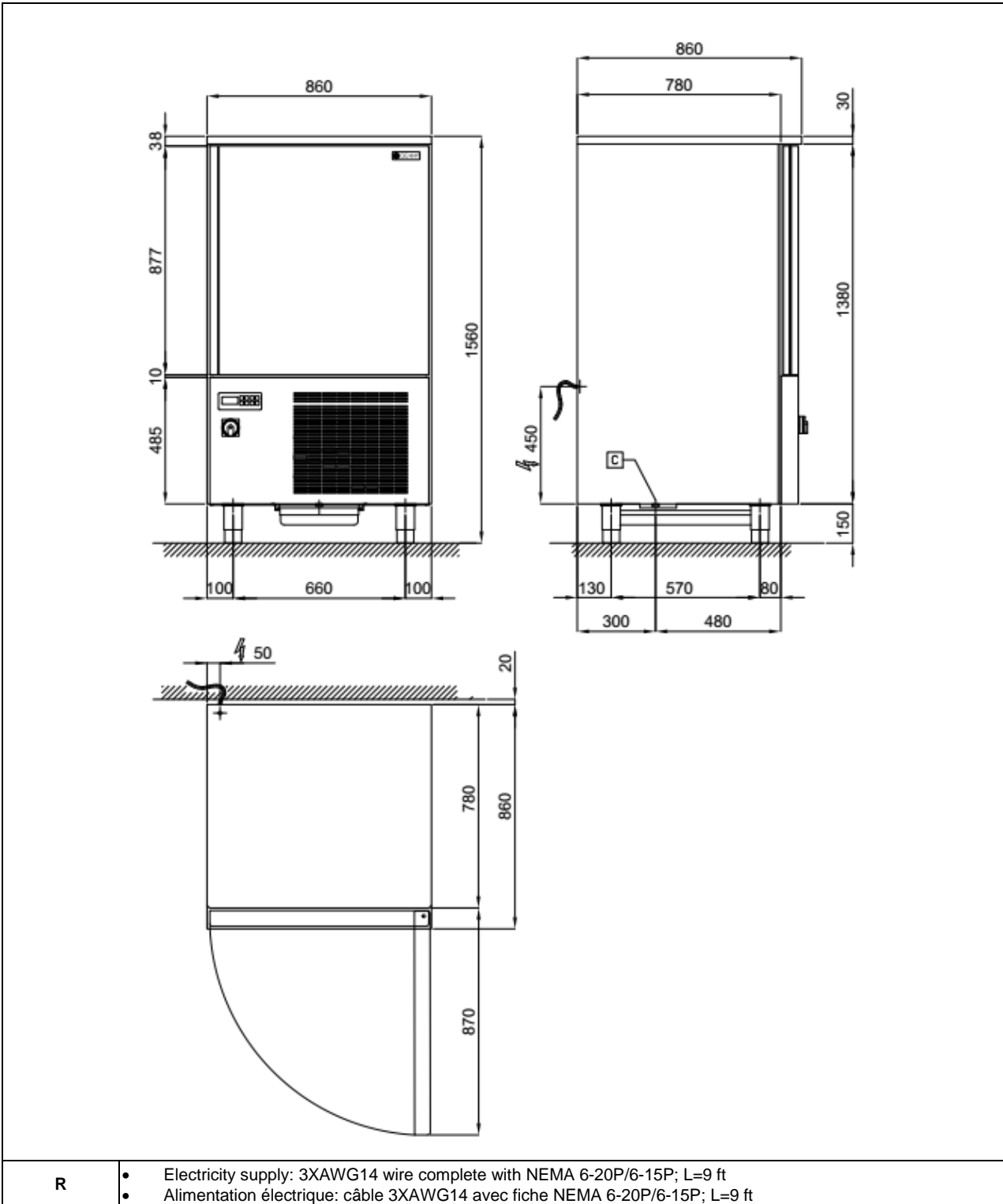

Fig. 5/b

3.2 – DESCRIPTION OF BLAST CHILLER AND ITS USE

Blast chillers are appliances with a powerful refrigeration system that can rapidly reduce the temperature at the core of food. Ideal for use in kitchens, bakeries and ice cream establishments.

The machine's main work cycles are **CHILLING** and **FREEZING**. Each cycle includes two different end of cycle modes at the point at which holding commences: **temperature controlled** (the probe inserted into the core of the product ends the cycle when it reaches the set temperature) or **time controlled** (the cycle ends as soon as the set time expires).

3.2.1 – MAIN PARTS

The appliance comprises the following parts:

- body;
- condenser unit (ref. 2, fig. 6);
- evaporator unit (ref. 1, fig. 6);
- control panel (ref. 3, fig. 6)

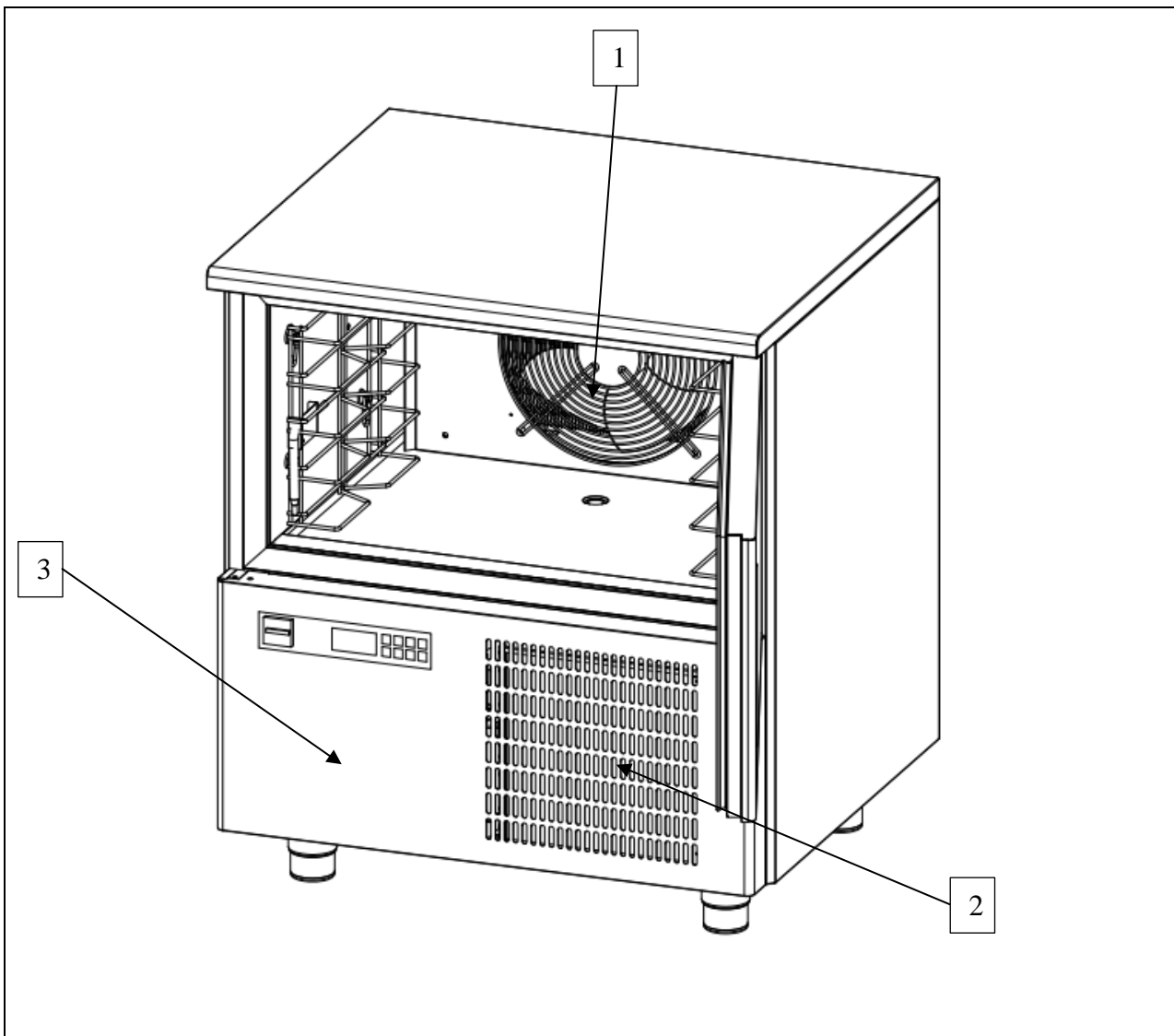

Fig. 6

3.3 – NOISE

The appliance is designed and built to keep its noise level as low as possible.

3.4 –AMBIENT CONDITIONS

Installation site	Bakeries, confectioner's, ice cream makers, and kitchens in general
Relative humidity	≤ 80% without condensation
Climatic class	5 +104°F 40%HR
Tab. 2	

4 – TRANSPORT AND HANDLING

4.1 – TRANSPORT

The packing used is suitable for the type, dimensions and weight of the appliance and ensures that it is protected and remains undamaged during transport and delivery to the purchaser.

The blast chiller must be placed in position and kept upright on a pallet and surrounded by its packing box throughout its journey.

The blast chiller is handed over to the carrier ready to be handled.



The appliance must never be overturned.



The packing must be well placed on the platform of the means of transport and secured by appropriate ropes.



Take the utmost care when lifting and positioning the blast chiller, so as to avoid serious damage to persons or things. The manufacturer declines all responsibility if the indications for lifting and transport the blast chiller are not observed.



Ambient temperature must never drop below 39°F during transport.

Once the blast chiller has been unpacked, the packing material must be eliminated and/or re-used in compliance with current waste disposal regulations in the countries where the appliance will be used.

4.2. – HANDLING THE PACKED BLAST CHILLER



Take great care when lifting and handling the blast chiller; there is an injury hazard in handling loads, which may also be fatal.



All handling and lifting operations must be carried out with great caution, making sure that all personnel is strictly at a safety distance and that no-one stands under suspended loads, be they still or in motion.



Before starting the operation, check the whole appliance handling area to identify any dangerous points.



Ambient temperature must never drop below 39°F during transport.

AUTHORIZED PERSONNEL

Specialised fork-lift truck operator.

Individual safety devices:

- safety shoes;
- safety gloves.

Personnel carrying out such operations must not wear rings, wrist watches, jewellery, loose or unfastened garments, such as, for example, ties, torn garments, scarves, unbuttoned jackets or blouses with open zips, etc. In general, personnel must wear safety apparel.

4.2.1 – WEIGHT AND DIMENSIONS

Model		BCB/05US	BCB/10US	
Dimensions	inches	33 7/8 X 30 3/4 X 37 3/4	33 7/8 X 33 7/8 X 61 3/8	
Weight	lb	238	348	
				Tab.3

4.2.2 – MEANS REQUIRED

- To lift the appliance use a fork-lift truck of suitable minimum capacity.



The use of unsuitable equipment can cause accidents to those involved in the operation and/or damage to the appliance.

The manufacturer declines all responsibility for improper non-compliant use of equipment for lifting, transport and handling.

5 – INSTALLATION



Use the utmost care in handling the appliance, so as to avoid damage to persons or things.



Do not start the appliance if there are faults on the control panel or parts are damaged.

AUTHORIZED PERSONNEL

Specialised electrician.

Individual safety devices:

- safety shoes;
- safety gloves.

Personnel carrying out such operations must not wear rings, wrist watches, jewellery, loose or unfastened garments, such as, for example, ties, torn garments, scarves, unbuttoned jackets or blouses with open zips, etc. In general, personnel must wear safety apparel.

5.1 – PREPARATION FOR INSTALLATION

For installation prepare an area of manoeuvre suitable for the dimensions of the appliance (see fig. 5) and the chosen lifting equipment.

The installation site must be prepared with all the connecting systems required for the appliance to work.

Choose an installation site with requisites that will allow the appliance to be used safely. The area must provide good support, with a solid flat floor whose finish will ensure a suitable and safe working place for personnel.

Install the appliance in a place with natural and/or artificial light suitable for the operations to be carried out (in compliance with specific regulations).

5.2 – UNPACKING



Check that the packing has not been damaged during transport.

5.2.1 – MEANS REQUIRED

Use a fork-lift truck or equivalent equipment to lift the appliance.



The use of unsuitable equipment can cause accidents to those involved in the operation and/or damage to the appliance.

The manufacturer declines all responsibility for improper non-compliant use of equipment for lifting, transport and handling.

5.2.2 – UNPACKING PROCEDURE



All the handling and unpacking operations must be carried out with extreme care, making sure that all personnel is strictly at a safety distance and that no-one stands under suspended loads, be they still or in motion.

To unpack the appliance just remove its cardboard wrapping. Take the appliance off the pallet, lifting it by means of a suitable fork-lift truck; the forks should be placed under the appliance **taking care not to damage the two water tray runners.**



AFTER INSTALLING THE APPLIANCE, WAIT AT LEAST TWO HOURS BEFORE TURNING IT ON.

5.3 – HANDLING THE BLAST CHILLER

5.3.1 – MEANS REQUIRED

See paragraph 5.2.1.



The use of unsuitable equipment can cause accidents to those involved in the operation and/or damage to the appliance.
The manufacturer declines all responsibility for improper non-compliant use of equipment for lifting, transport and handling.

5.3.2 – HANDLING THE UNPACKED BLAST CHILLER



All the handling and unpacking operations must be carried out with extreme care, making sure that all personnel is strictly at a safety distance and that no-one stands under suspended loads, be they still or in motion.

To move blast chillers on wheels, release the brakes on the wheels and push, taking care to block the brakes again when the appliance is in its permanent position.

To move blast chillers on feet, lift them with a suitable fork-lift truck; the forks should be placed under the appliance, **taking care not to damage the two water tray runners.**

5.4 – BLAST CHILLER ASSEMBLY

The blast chiller is delivered to the customer assembled in all its parts.

Remove the water tray from the chamber and place it in position along the runners placed under the appliance between the feet.

6 – SETTING UP



AFTER INSTALLING THE APPLIANCE, WAIT AT LEAST TWO HOURS BEFORE TURNING IT ON.

6.1 – CONNECTIONS

6.1.1 – ELECTRICAL CONNECTION



Electrical connection must be made by a specialised electrician.

- Check that the power supply voltage given on the ID plate corresponds to that available at the installation site.
- Connections must be made to current regulations; the supply mains must have an efficient earthing system compliant with electricity regulations in the country; this is a responsibility of the customer.
- Do not make tight bends on the power lead and do not place any object whatsoever on top of it.



If it is necessary to unplug the mains supply, first make sure the main switch is on OFF.



The manufacture declines all responsibility for damage or accidents caused by failure to observe such regulations.

ELECTRICAL CONNECTION PROCEDURE

The appliance is supplied by the manufacturer complete with power plug. Just connect the power plug to a socket at the installation site; the system must be carried out to current regulations.

The electricity supply at the installation site must have the following requisites:

- Voltage: 115 Vac (BCB/05US); 230 Vac (BCB/10US)
- Frequency: 60 Hz

6.2 – PRELIMINARY CHECKS

The electrician fitter shall train the operator in the correct use of the blast chiller and give the basic notions of maintenance.

METHOD

The operations to prepare the blast chiller for initial start-up must be carried out by a specialised engineer, in the presence of the operator, who can acquire information to carry out certain routine maintenance and cleaning.

Before starting up the appliance, a series of checks and inspections must be carried out for the purpose of preventing errors or accidents during start-up.

- Check that the appliance has not been damaged during transport.
- Check with special care for any damage to the electrical box, push button control panel, wiring and pipes.
- Check that all external power sources have been connected properly.
- Check that the machine is perfectly level.

6.2.1 – REGULATION



Regulation carried out by unauthorized personnel may damage the appliance and expose the operator to serious hazards. Regulation carried out by unauthorized personnel is considered tampering with the appliance and as such null the warranty and relieve the manufacturer of any responsibility.

7 – USE



AFTER INSTALLING THE APPLIANCE, WAIT AT LEAST TWO HOURS BEFORE TURNING IT ON.

7.1 – USE FORSEEN

Blast chillers are appliances with a powerful refrigeration system that can rapidly reduce the temperature at the core of food. Ideal for use in kitchens, bakeries and ice cream establishments.

The machine's main work cycles are **CHILLING** and **FREEZING**. Each cycle includes two different end of cycle modes at the point at which holding commences: **temperature controlled** (the probe inserted into the core of the product ends the cycle when it reaches the set temperature) or **time controlled** (the cycle ends as soon as the set time expires).

- **SOFT CHILLING**. Positive “delicate” temperature reduction (+37°F). Food just out of the oven is quickly taken to a temperature of 37°F in no longer than 90', thus inhibiting bacterial proliferation and avoiding dehydration of the cooked food due to evaporation. Food treated in this way can be preserved perfectly for 5-7 days without altering its original qualities.
- **HARD CHILLING**. Positive “rapid” temperature reduction (+37°F). Also lasts for a maximum of 90'. This type of process is used when the food to be chilled is thicker than an inch (i.e. large joints) and with dense or fatty food. During this phase the appliance **reaches -4°F air temperature** and provides to accelerate penetration of the cold into the food.
- **FREEZING**. Deep freezing or freezing (0°F). During this phase the appliance **reaches -40°F air temperature**. This work cycle will take the core of the food to a temperature of 0°F in less than four hours (240'). The speed of the process avoids the formation of macrocrystals, ensuring that when it is used the thawed food has its original consistency, colour and quality.
- **HOLDING**. At the end of both the chilling and freezing cycles the machine will automatically go to the set holding temperature.

7.2 – UNFORSEEN USE















Blast chillers cannot be used for purposes other than those described in point **7.1**. In particular the appliance is not suitable for storing food for an indefinite period.

7.3 – CONTROL PANEL









Fig. 7

The buttons on the control panel are as follows:

		BUTTON 0/1, START/STOP	With the machine OFF (0) press once to go to STANDBY (1). With the machine on STANDBY press once to START a cycle. When a cycle is in progress press once to STOP it. In whatever situation the machine is, if the button is held down for 3 seconds the circuit board is cut OFF.
		- AND + BUTTONS	Used to increase or decrease the value shown on the display.
		DEFROST BUTTON	With the machine on STANDBY and/or during the storage, press once to start a defrost cycle.
		CHILLING BUTTON	With the machine on STANDBY press once to select a time controlled chilling cycle. Keep held down the button for 3 second in order to start the continuous cycle
		HARD/SOFT BUTTON	With the cycle selected, press once in order to select HARD or SOFT process.
		FREEZING BUTTON	With the machine on STANDBY press once to select a time controlled freezing cycle.
		AUXILIARY BUTTON	Press this button in order to use the accessory, as UV lamp, warmed probe, where installed.

The icons on the control panel display are:

	OFF	Illuminated when the machine is OFF; not illuminated in all other situations.
	FAHRENHEIT / CELSIUS	Can be illuminated in red or green to indicate the temperature measuring unit.
	CHILLING AND FREEZING	Flash when the cycles they refer to are in progress; remain illuminated during the following holding cycle.
	TEMPERATURE	Illuminated during a temperature controlled cycle
	TIME	Illuminated during a time controlled cycle.
	HOLDING	Illuminated or flashing during the holding period.
	CONTINUOUS CYCLE	Illuminated or flashing during the pre-cooling phase, also CONTINUOUS CYCLE.

HARDHARD BLAST
CHILLER/FREEZING

Illuminated during the hard blast chilling/hard blast freezing.



DEFROST

Illuminated during the defrost.

AUX



AUXILIARY

Illuminated during the on of the accessory, as UV lamp, warmed probe, where installed



7.4 – CONTROL PROCEDURES



The entire appliance is controlled by an electronic circuit board.

When the machine is powered the appliance display illuminates fully for a “lamp-test” lasting a few seconds, at the end of which it returns to the condition it was in before being switched off. In particular, if a cycle was in progress it will re-start from the point at which it was interrupted.

With the circuit board OFF the display is completely off, except for the  icon. Press the  button to turn off the  icon on the display and go to STANDBY, which shows the chamber temperature in blue.

The various machine functions can be activated by using the controls on the panel and observing the indications on the display.

With the circuit board in STANDBY you can go from one cycle to another simply by pressing , , .

With the circuit board on STANDBY and a cycle selected you can start the cycle by pressing  (START). Pressing  (STOP) once blocks the cycle in progress.

The buzzer can be silenced, whatever its cause, by pressing any button.

Whatever situation the machine is in, holding down  for 3 seconds cuts OFF the circuit board.

7.5 – USE PROCEDURES

Clean the inside of the chamber before using the machine.

After installation or a prolonged idle period, it is good practice to operate the empty appliance until it reaches the set temperature. To achieve good output from the blast chiller it is advisable to place the food inside in such a way as to assist air circulation: do not obstruct the fan, do not stack trays on top of each other, distribute the load neatly and do not cover the containers with lids or cling film.

In order to avoid altering the food, it is also advisable not to overload the machine beyond the permitted load, not to use pieces thicker than 2-3” and to limit door opening as much as possible.

Clean and sterilise the core probe before use. The probe must be placed in the centre of the largest joint or piece, taking care that the point does not go right through the food to come into contact with the tray.

To improve the efficacy of the working cycle is recommended to perform a pre-cooling of the cell, by turning on the machine at least 15 min before insert the product, both in killing and freezing.





When a temperature controlled cycle is selected the electronic circuit board checks the temperature read by the chamber probe and core probe to assess correct insertion of the probe (AUTOMATIC probe identification). This check lasts just over two minutes, at the end of which the cycle proceeds normally if the probe is properly inserted. This check lasts just over 2 minutes, accordingly with established parameters, at the end of which the cycle proceeds with a temperature controlled cycle if the probe is properly inserted. In this case the temperature of the probe will be showed and the icon  will remain turned on.



If the test has a negative result, after a minute of buzzer’s alarm, the display will show the icon  and the cycle will proceed with a time controlled cycle.

7.6 – SOFT CHILLING





7.6.1 – SELECTING AND SETTING OF SOFT CHILLING CYCLE

Load the machine suitably with the food to be chilled, place the core probe into the food and close the door.

With the appliance on STANDBY press : the display will show the set point temperature of the room referred to **23°F** cycle, in the meantime the icons  and  flash. Use the  and  buttons to edit this value.

Press  (START) to start the cycle: the display will show the temperature of the room and the icons  and  will remain on. As already explained, once confirmed the cycle, the device does an automatic identification of probe's insertion (around 2 minutes), at the end of which the cycle will be confirmed or by probe or by time. All this process will be made AUTOMATICALLY.







If the test has a positive result, the device will confirm the temperature controller cycle (probe) and the display will show the temperature of the probe.

Otherwise, if the result is negative, after buzzer's alarm and visual signalling of the flashing icon , the display will show the icon  and the cycle will change in time controlled cycle. Use the  and  buttons to edit this value.

During the visualization of the residual time, it is possible to change the temperature of the room by pressing the buttons



It is possible select the time controlled cycle DIRECTLY, bypassing the automatic phase of probe's recognizing.

With the appliance on STANDBY press **TWICE** : the display will show the duration of the cycle 90 min, in the meantime the icons  and  flash. Use the  and  buttons to edit this value. Than press  (START) in order to start the cycle.

Once finish the time relative to 90' cycle or once reaches the core temperature of 37°F, the device automatically starts the conservation cycle, 36°F rooms, previously reported by the buzzer's alarm.





On the display will appear the icon 

The cycle can be interrupted at any time by pressing  (STOP): press  (START) again in order to restart again the cycle.



7.7 – HARD CHILLING

7.7.1 – SELECTING AND SETTING OF HARD CHILLING CYCLE





Load the machine suitably with the food to be chilled, place the core probe into the food and close the door.

With the appliance on STANDBY press : the display will show the set point temperature of the room referred to **23°F** cycle, in the meantime the icons  and  flash. Use the  and  buttons to edit this value.

Press once the  button in order to start with hard phase. Also the symbol HARD will flash on the display.







Press  (START) to start the cycle: the display will show the temperature of the room and the icons  and  will remain on. As already explained, once confirmed the cycle, the device does an automatic identification of probe's insertion (around 2 minutes), at the end of which the cycle will be confirmed or by probe or by time. All this process will be made AUTOMATICALLY.

If the test has a positive result, the device will confirm the temperature controller cycle (probe) and the display will show the temperature of the probe.

Otherwise, if the result is negative, after buzzer's alarm and visual signalling of the flashing icon , the display will show the icon  and the cycle will change in time controlled cycle. Use the  and  buttons to edit this value.

During the visualization of the residual time, it is possible to change the temperature of the room by pressing the buttons



With the appliance on STANDBY press **TWICE** : the display will show the duration of the cycle 90 min, in the meantime the icons  and  flash. Use the  and  buttons to edit this value. Than press  (START) in order to start the cycle.

Once finish the time relative to 90' cycle or once reaches the core temperature of 37°F, the device automatically starts the conservation cycle, 36°F rooms, previously reported by the buzzer's alarm.





On the display will appear the icon .



The cycle can be interrupted at any time by pressing  (STOP): press  (START) again in order to restart again the cycle.

7.8 – FREEZING





7.8.1– SELECTING AND SETTING OF FREEZING CYCLE

Load the machine suitably with the food to be frozen, place the core probe into the food and close the door.

With the appliance on STANDBY press : the display will show the set point temperature of the room referred to - 40°F cycle, in the meantime the icons  and  flash. Use the  and  buttons to edit this value.

Press  (START) to start the cycle: the display will show the temperature of the room and the icons  and  will remain on. As already explained, once confirmed the cycle, the device does an automatic identification of probe's insertion (around 2 minutes), at the end of which the cycle will be confirmed or by probe or by time. All this process will be made AUTOMATICALLY.







If the test has a positive result, the device will confirm the temperature controller cycle (probe) and the display will show the temperature of the probe.

Otherwise, if the result is negative, after buzzer's alarm and visual signalling of the flashing icon , the display will show the icon  and the cycle will change in time controlled cycle. Use the  and  buttons to edit this value.

During the visualization of the residual time, it is possible to change the temperature of the room by pressing the buttons



You can **DIRECTLY** select the cycle time, bypassing the automatic stage of probe recognition.

With the appliance on STANDBY press **TWICE** : the display will show the duration of the cycle 240 min, in the meantime the icons  and  flash. Use the  and  buttons to edit this value. Than press  (START) in order to start the cycle.



Once finish the time relative to 240' cycle or once reaches the core temperature of 0°F, the device automatically starts the conservation cycle, -13°F rooms, previously reported by the buzzer's alarm.

On the display will appear the icon .

The cycle can be interrupted at any time by pressing  (STOP): press  (START) again in order to restart again the cycle.

7.9 – SPECIAL USES

7.9.1 – PRE-CHILLING FUNCTION OR CONTINUOUS CYCLE.

If the temperature of the food to be chilled is very high (above 149°F) it is advisable to pre-chill it in the following way: press the button  for some seconds, the device will start and the led  will flash. Once reached the set point (-31°F), the led remains on and it will be possible to choose any type of cycle or load the device with the foods you have to chill/freeze. The new selected cycle will “overwrite” the continuous cycle, without turning off the device previously.

The continuous cycle is ideal for ice-cream laboratories, as the working cycles are very frequent (HARDERING). It is necessary to have just the room temperature as parameter. Instead time is not a parameter necessary.

7.9.2 – DEFROST

The machine evaporator is defrosted by stopping the compressor. It can be **Automatic** or **Manual** and is shown on the display by illumination of the wording “**def**” first fixed then, during the drip flashing.

Automatic defrost can only take place during the holding period, at intervals of 6 hours with a duration of 15' and the evaporator temperature does not exceed 46°F.

Manual defrosting can be activated when the machine is on STANDBY and the evaporator temperature does not exceed 46°F, by pressing . Because on STANDBY the compressor is already off forced ventilation takes place during Manual defrost, so it is advisable to keep the door open throughout the cycle.

7.9.3 – LONG IDLE PERIODS

Turn the machine OFF by pressing  for three seconds, switch OFF the main switch, then unplug.

Clean the machine thoroughly (see paragraph 8.2) and make sure the door is left open at the end of the operation and throughout the idle period.

8 – MAINTENANCE

8.1 – SPECIAL PRECAUTIONS



Contact the manufacturer for any anomalies not described in this manual; contact the manufacturer also for any doubts during the maintenance operations described herein. Maintenance carried out by unauthorized personnel may damage the appliance and expose the operator to serious hazards. Maintenance carried out by unauthorized personnel is considered tampering with the appliance and therefore nulls the warranty and relieves the manufacturer of any responsibility.



Any routine or extraordinary maintenance operation that requires the electric box to be opened or the machine to be dismantled, even partially, must be carried out only after the appliance has been switched off the main switch, and unplugged.



Any maintenance operations carried out on a live machine may cause people serious accidents which may also be fatal.



The safety devices must be deactivated only by authorized personnel, who will guarantee safety for people and avoid damage to the machine. The safety devices must be carefully activated again after carrying out maintenance.

During maintenance or repairs unauthorized persons must keep a safe distance from the appliance.

Observe the intervals prescribed or indicated in this manual for making inspections.

At the end of maintenance or repairs the appliance can be started only after the specialist engineer has made sure that:

- all the work has been fully carried out;
- the safety systems are active;
- the appliance is working perfectly;
- no-one is working on the appliance.

8.2 – ROUTINE MAINTENANCE

8.2.1 – ROUTINE MAINTENANCE TABLE (TAB. 5)

Component	Type of operation	Timing	Responsibility	Method
Chamber	Cleaning	When needed	Appliance operator	See para. 8.2.2
External part	Cleaning	When needed	Appliance operator	See para. 8.2.3
Condenser	Cleaning	Every 30 days	Appliance operator	See para. 8.2.4
Core probe	Cleaning	Every cycle	Appliance operator	See para. 8.2.5

Tab. 5

8.2.2 –CLEANING THE CHAMBER

Carry out this operation whenever necessary.

APPLIANCE STATUS:

- **I/O main switch in position “O” (OFF);**
- **power supply plug disconnected from the mains.**

AUTHORIZED PERSONNEL

Appliance operator.

METHOD

Clean very carefully the internal part of the chamber, the door closure surface (ref. 1 fig. 8) and gasket (ref. 2 fig. 8), using a non-abrasive sponge soaked in neutral detergent. Rinse with a sponge soaked in water and dry with a clean cloth. Proper cleaning of the inside of the appliance prevents the formation of bad odour which could affect the end product negatively.



Use exclusively water and non-abrasive neutral detergent for cleaning. The use of different products could damage the surface of the appliance and compromise the quality and healthiness of the product being processed.
Do not use abrasive sponges.



When cleaning do not use cloths that leave lint.



Do not use water jets to clean the appliance.

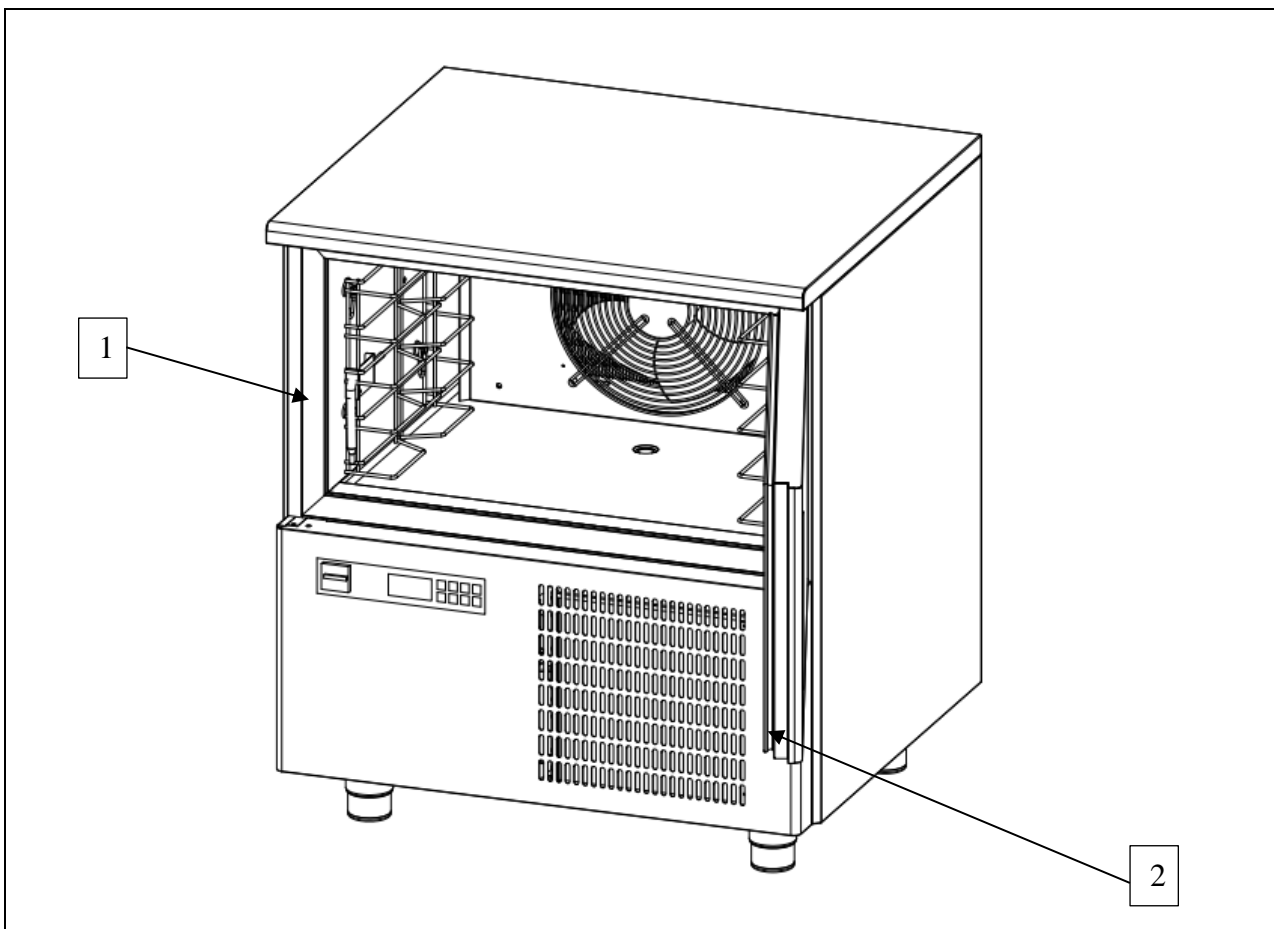

Fig. 8

8.2.3 – CLEANING THE OUTSIDE OF THE APPLIANCE

Carry out this operation whenever necessary.

APPLIANCE STATUS:

- I/O main switch in position “O” (OFF);
- power supply plug disconnected from the mains.

AUTHORIZED PERSONNEL

Appliance operator.

METHOD

Clean the outer surface of the appliance (steel base and panelling), using a non-abrasive sponge soaked in neutral detergent. Rinse with a sponge soaked in water and dry with a clean cloth.



Use exclusively water and non-abrasive neutral detergent for cleaning. The use of different products could damage the surface of the appliance and compromise the quality and healthiness of the product being processed.
Do not use abrasive sponges.



When cleaning do not use cloths that leave lint.

8.2.4 – CLEANING THE CONDENSER

Carry out this operation every 30 days.

APPLIANCE STATUS:

- I/O main switch in position “O” (OFF);
- power supply plug disconnected from the mains.

AUTHORIZED PERSONNEL

Appliance operator.

METHOD

To ensure that the appliance works properly and efficiently, the air condenser (ref. 1 fig. 9) must be kept clean so that the air can circulate freely. This operation should be carried out every 30 days. Remove the control panel by loosening the screws (ref. 2 and 3 fig. 9). Clean with a non-metal brush to remove all the dust and fluff from the fins. It is advisable to use a vacuum cleaner so that dust does not float in the air. If there are greasy deposits, eliminate with a brush soaked in alcohol. **DO NOT SCRAPE THE SURFACES WITH POINTED OR ABRASIVE OBJECTS.**

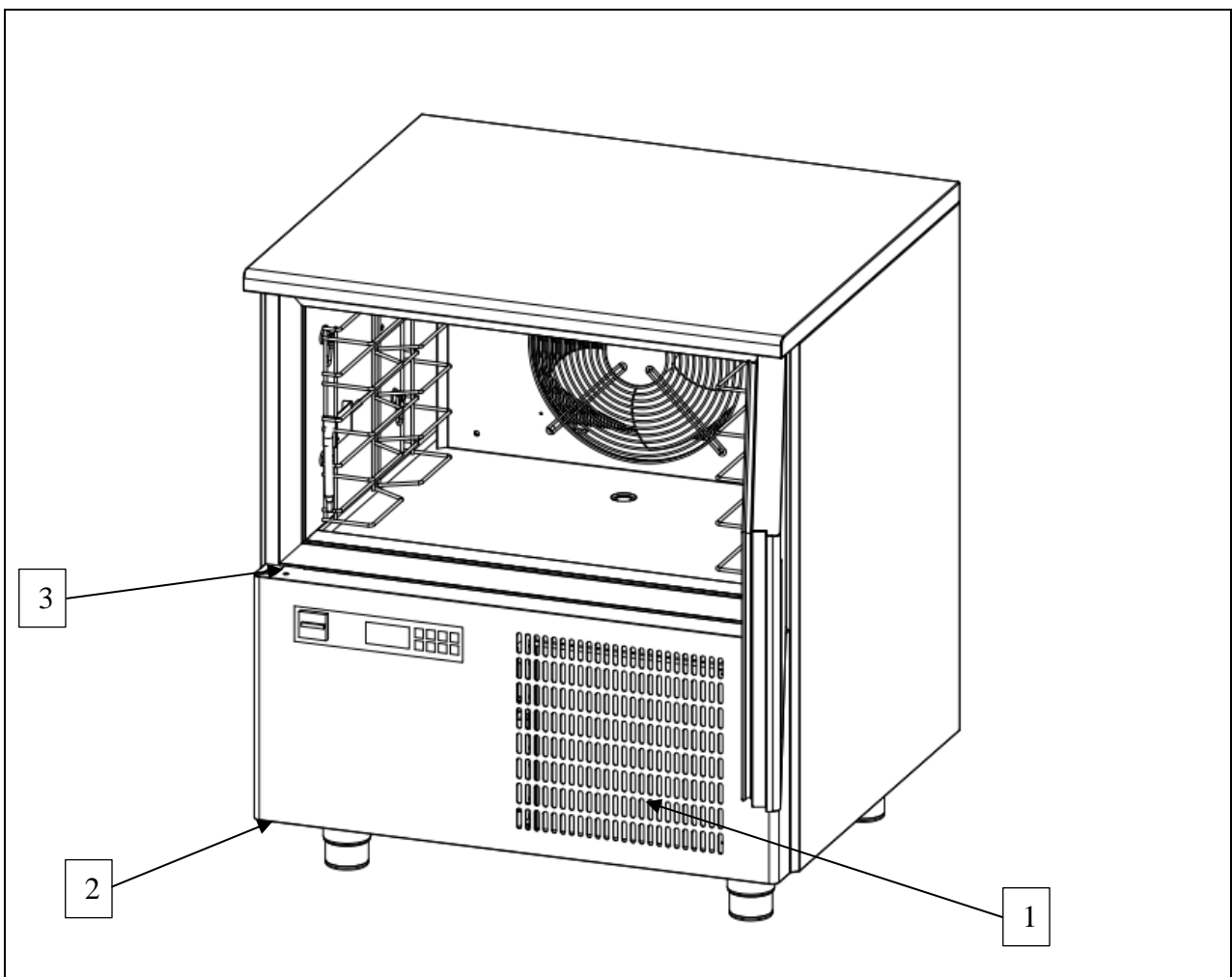

Fig. 9



The condenser has sharp edges. When carrying out the operations mentioned above, wear safety gloves, goggles and face masks.



Do not use direct water jets to clean the appliance.

8.2.5 – CLEANING THE CORE PROBE

Carry out this operation at every cycle.

APPLIANCE STATUS:

- I/O main switch in position “O” (OFF);

AUTHORIZED PERSONNEL

Appliance operator.

METHOD

The core probe (ref. 1 fig. 10) must always be cleaned before a new cycle so as to avoid polluting the product in any way. Remove all residue by means of a sponge soaked in neutral detergent. Rinse with lots of water and apply a sterilising product.

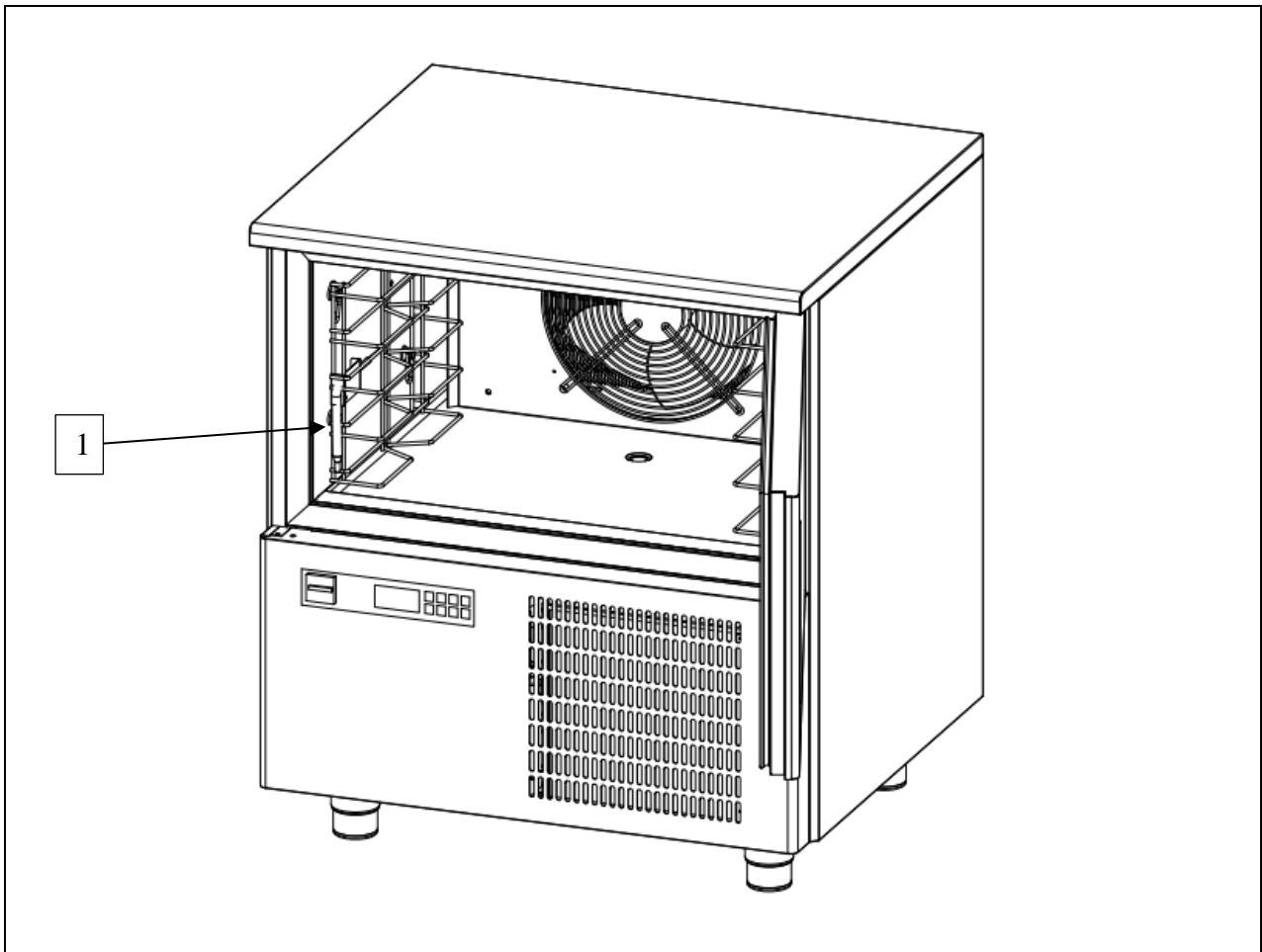

Fig. 10



Do not pull the probe wire; you may damage it.



The probe has a very pointed end. During cleaning always wear safety gloves and take the utmost care.

8.3 – EXTRAORDINARY MAINTENANCE

If the appliance needs extraordinary maintenance, or if operating anomalies occur that are not described in this manual, contact the manufacturer.



8.4 – OPERATING ANOMALIES AND FAULTS

It is important to remember that whatever machine status is, pressing the button  for 3 seconds turns it OFF and switching OFF the main switch.

When any operating anomaly occurs the buzzer sounds intermittently and red wording appears on the display. Whatever the reason for the buzzer, it can be silenced by pressing any button.

8.4.1– ALARMS

Possible alarm warnings on the display are as follows:

- “ **tiME** ” alarm temperature chilling or temperature freezing are not reached within the maximum duration (HACCP). This alarm doesn't have any effect, it will be just memorized..
- “ **AL** ” alarm minimum temperature. During any kind of cycle, this alarm doesn't have any effect.
- “ **AH** ” alarm maximum temperature. During any kind of cycle, this alarm doesn't have any effect.
- “ **HP** ” high pressure switch alarm. On STANDBY it has no effect. During any other work stage it causes the cycle to stop and go onto STANDBY. Eliminate the cause of the alarm then turn off the machine by pressing  for 3 seconds, then press  (START) to re-start. This alarm can be caused by high ambient temperature (above that admitted; see para. **3.4**) or a dirty condenser (which must be cleaned as described in para. **8.2.4**).
- “ **id** ” door open alarm. This alarm doesn't have any effect and it will finish by closing the door.

8.4.2– ERRORS

Errors recognized by the electronic controller are:

- “ **Pr 1** ” chamber probe error. On STANDBY impedes cycle start. On Chilling or Freezing causes the cycle to stop and the machine to go onto STANDBY. During the Holding period the cycle is not interrupted and the compressor works cyclically to ensure maintenance of the chamber temperature. Check probe connection and replace if necessary.
- “ **Pr 2** ” core probe error. On STANDBY impedes the start of a temperature controlled cycle. On temperature controlled Chilling or Freezing causes the machine to go to a time controlled cycle. During the Holding period it has no effect. Check probe connection and replace if necessary.
- “ **Pr 3** ” evaporator probe error. On STANDBY, Chilling or Freezing and during Holding it has no effect. If defrost is taking place it will end by time-out.

9 – DISMANTLING



Contact the manufacturer to dismantle the appliance in any way.

10 – DISPOSAL

10.1 – DISPOSAL METHOD

APPLIANCE STATUS

- **electronic circuit board in position “O” (OFF);**
- **I/O main switch in position “O” (OFF);**
- **power supply plug disconnected from the mains.**

METHOD

The appliance is made of ferrous materials, electronic components and plastics. If it needs to be disposed of, separate the various components according to the material of which they are made, to simplify separate waste collection or re-use of the parts. The appliance must be disposed of separately from urban waste.

No special instructions apply to the dismantled appliance. Dispose of it through the special operators or return to the dealer, if the law provides for this (also see “Information to users regarding waste disposal in the European Union” below).

For disposal consult the laws applicable in the country where the appliance is used (also see “Information to users regarding waste disposal in the European Union” below).



TAKE CARE: THE APPLIANCE CONTAINS REFRIGERANT GAS THAT MUST BE CONTROLLED AND RECOVERED ACCORDING TO THE REGULATIONS OF THE COUNTRY IN WHICH DISPOSAL WILL TAKE PLACE.



Consult the fitter for any dismantling requirements.

INFORMATION TO USERS REGARDING WASTE DISPOSAL IN THE EUROPEAN UNION



The symbol of a crossed waste bin on the appliance indicates that at the end of its working life the product must be collected separately from other waste.

Therefore, at the end of the product's working life the user must take it to a suitable centre for the collection of electronic and electrical waste, or return it to a dealer when purchasing a new appliance of the same type.

Suitable separate waste collection of unwanted appliances and their forwarding to treatment, recovery and environmentally friendly disposal makes it possible to avoid potential negative effects on the environment and human health, and assists recycling and recovery of materials.

Unauthorized disposal of the product by the user is punished by the application of fines established by the countries in which the appliance is disposed of.

11 – SPARE PARTS

11.1 – ORDERING SPARE PARTS

Contact the manufacturer or authorized dealer to order spare parts.

12 – APPENDICES

The appliance comes with the following appendices:

- Declaration of conformity
- Electrical diagram
- Electrical approval report
- Assessment of vacuum, leakage and gas loading for cooling unit.

SIMBOLI GRAFICI PER CIRCUITI ELETTRICI

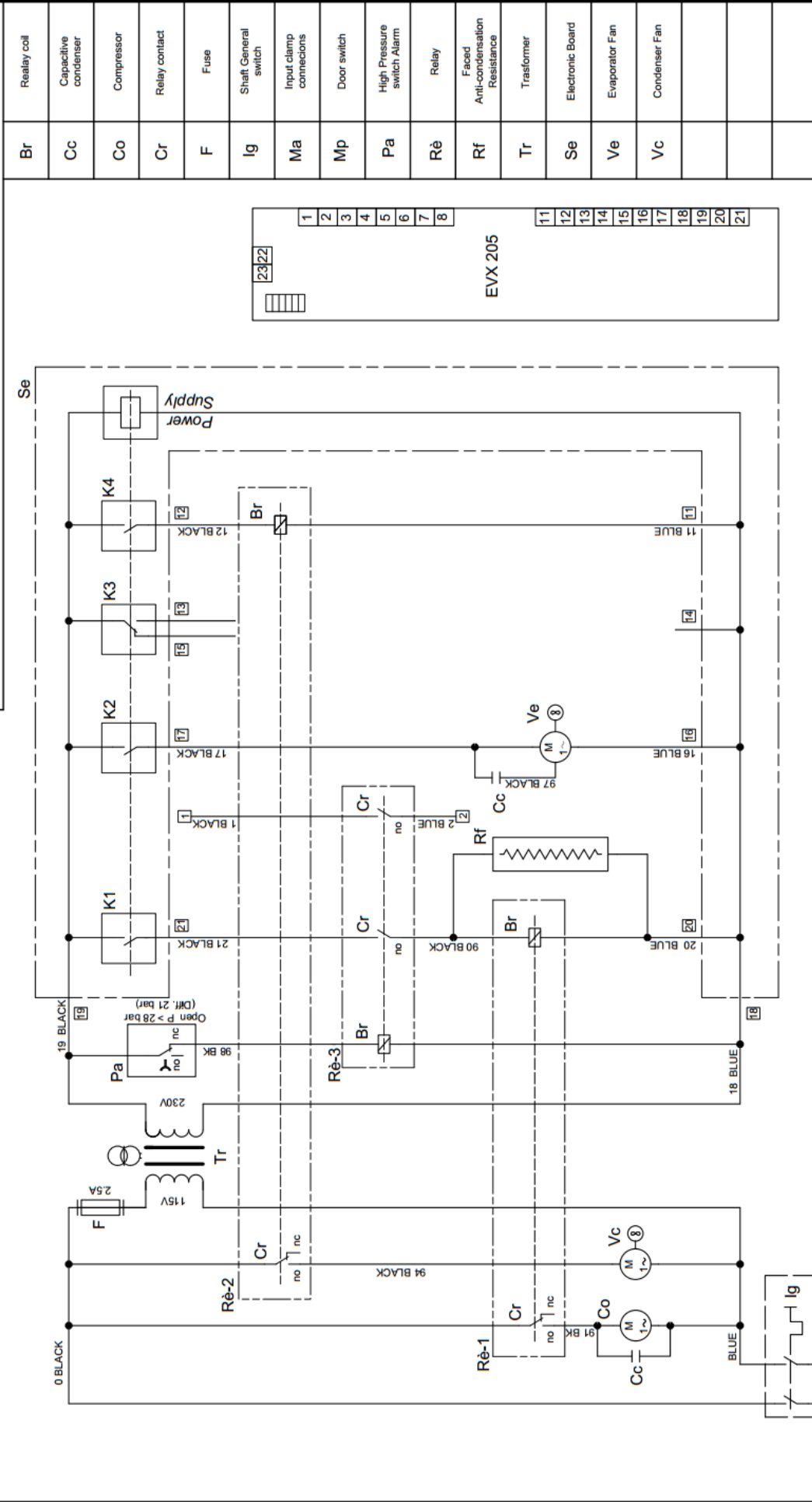

N° MOD.	DATA MOD.	DESCRIZIONE	VISTO
		CIRCUITO ELETTRICO BCB/3/5 115V-60HZ "UL"	
NOTE	DATA 20.12.2018 SCALA / DIS. FEDERICO F.	SEGGI GRAFICI SECONDO NORME IEC-617	
NOME FILE	ELECTRONIC BOARD EVX - 205		
		VISTO	

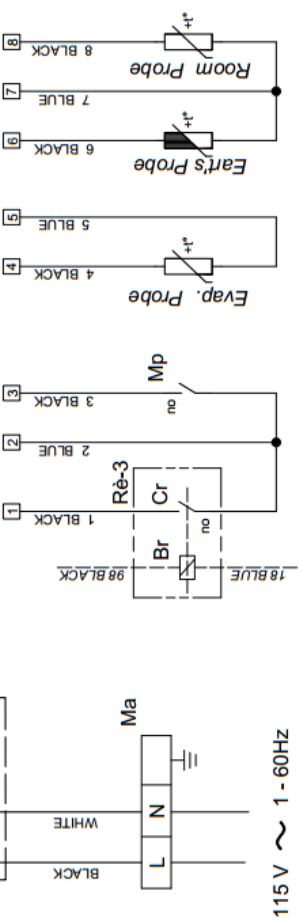

GEMM®

CODICE **703 0152 00**

SOSTITUISCE IL COD. DAL COD. SOSTITUITO

SIMBOLI GRAFICI PER CIRCUITI ELETTRICI

Br	Relay coil
Cc	Capacitive condenser
Co	Compressor
Cr	Relay contact
Ec	Compartment Electrolvalve
F	Fuse
Ig	Shaft General switch
Ma	Input clamp connections
Mp	Door switch
Pa	High Pressure switch Alarm
Pc	Condensation Pressure
Rè	Relay
Rf	Faced Anti-condensation Resistance
Tr	Trasformer
Se	Electronic Board
Ve	Evaporator Fan
Vc	Condenser Fan

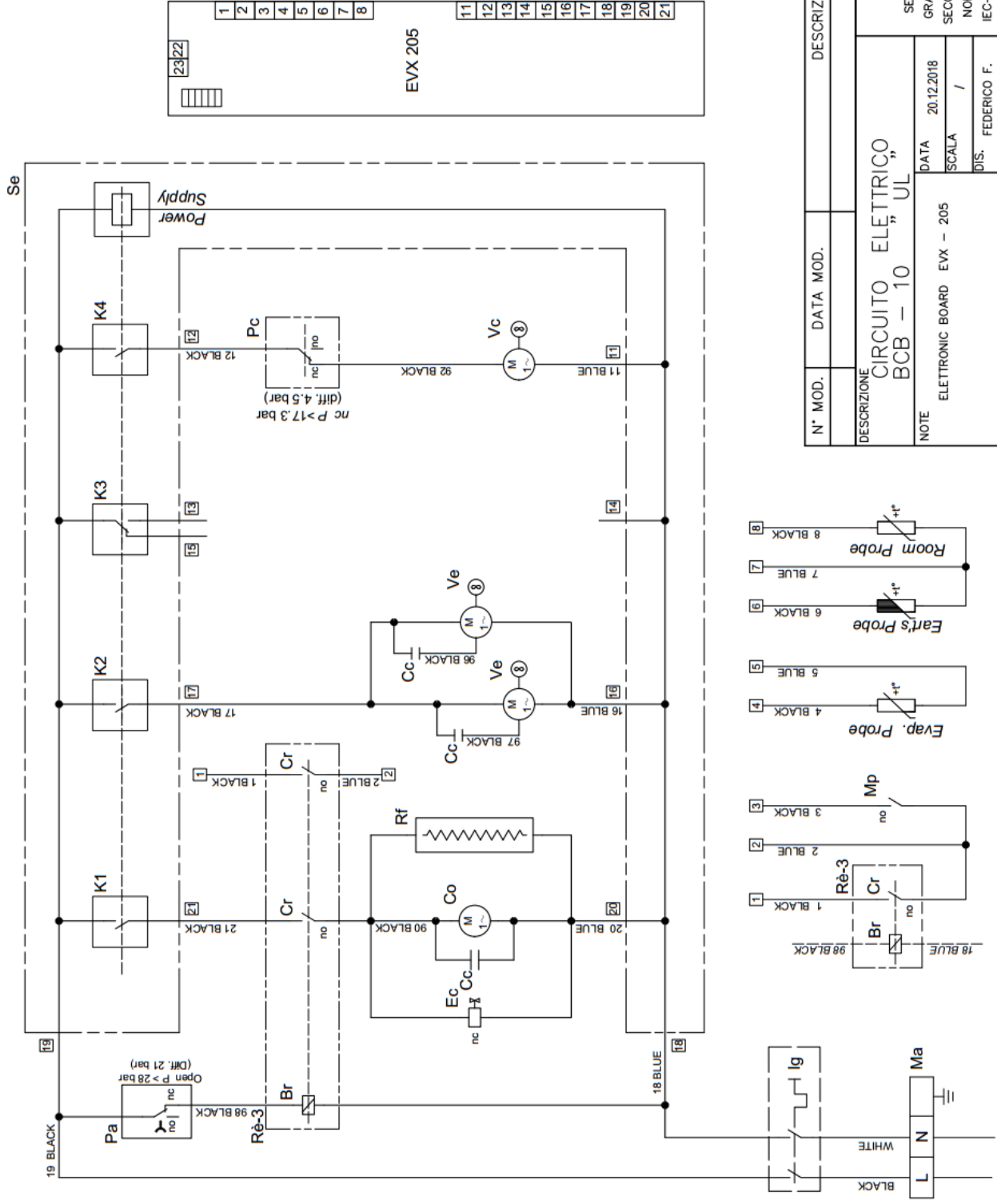

N° MOD.	DATA MOD.	DESCRIZIONE	VISTO
		CIRCUITO ELETTRICO BCB - 10 "UL"	
NOTE	DATA	SEGN	
ELECTRONIC BOARD EVX - 205	20.12.2018	GRAFICI	
	SCALA	SECONDO	
	/	NORME	
	DIS. FEDERICO F.	IEC-617	
NOME FILE	VISTO	SOSTITUISCE	
		IL COD.	
		SOSTITUITO	
		DAL COD.	
" - AI TERMINI DI LEGGE QUESTO DISEGNO E' DI NOSTRA PROPRIETA' E NON PUO' ESSERE USATO O RIPRODOTTO SENZA NOSTRA AUTORIZZAZIONE"			



CODICE
703 0149 00

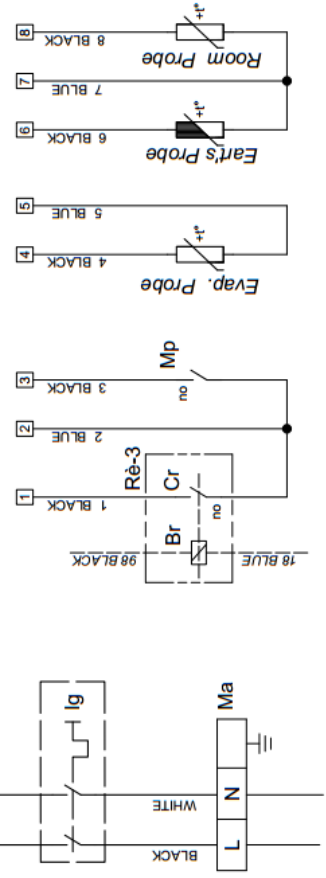

220 V ~ 1 - 60HZ

NOTE



GEMM srl

Via del Lavoro, 37 - Loc. Cimavilla - 31013 CODOGNE' (TV) - ITALY

T. +39 0438 778504 – F. +39 0438 470249

e-mail: info@gemm-srl.com - www.gemm-srl.com

Iscr.Reg.Impr. TV - CF e P.IVA 03441880261 - REA TV 272556

Registro Prod. AEE-TV n IT08020000001108

UNI EN ISO 9001:2008



CERT. N. 9105.GEMM