



## Aurora Refrigeration

Models RE-CN-0041E-HC, 0023E-HC, 0045E-HC, 0009E-HC

Items 59026, 59036, 59032, 59033

## Instruction Manual



*Revised - 12/09/2022*

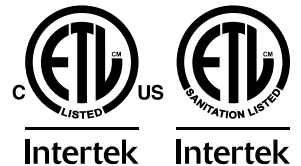

Toll Free: 1-800-465-0234  
Fax: 905-607-0234  
Email: [service@omcan.com](mailto:service@omcan.com)  
[www.omcan.com](http://www.omcan.com)

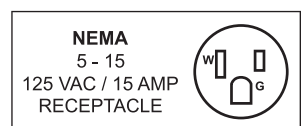

# ***Table of Contents***

Model RE-CN-0041E-HC / Model RE-CN-0023E-HC  
Model RE-CN-0045E-HC / Model RE-CN-0009E-HC

---

<b>Section</b>	<b>Page</b>
Disclaimer -----	3
General Information -----	4 - 5
Safety and Warranty -----	5 - 7
Technical Specifications -----	8
Installation -----	8 - 9
Maintenance -----	9 - 10
Troubleshooting -----	10 - 11
Parts Breakdown -----	12 - 19
Electrical Schematics -----	20 - 23
Notes -----	24 - 26
Warranty Registration -----	27

## *Disclaimer*

---

***OMCAN IS NOT RESPONSIBLE FOR ANY DAMAGES DUE TO WATER LEAKS. WARRANTY FOR WATER LEAKS IS VOID IF THE AMBIENT ROOM TEMPERATURE EXCEEDS 75°F AND 55% RELATIVE HUMIDITY, AND THE APPLIANCE DRAIN IS NOT CONNECTED DIRECTLY TO A FLOOR DRAIN.***

---

***OMCAN N'EST PAS RESPONSABLE DES DOMMAGES DUS AUX FUITES D'EAU. LA GARANTIE POUR LES FUITES D'EAU EST ANNULÉE SI LA TEMPÉRATURE AMBIANTE DE LA PIÈCE DÉPASSE 75°F ET 55% D'HUMIDITÉ RELATIVE, ET SI LE DRAIN DE L'APPAREIL N'EST PAS RACCORDÉ DIRECTEMENT À UN DRAIN DE PLANCHER.***

---

***OMCAN NO SE HACE RESPONSABLE DE LOS DAÑOS CAUSADOS POR FUGAS DE AGUA. LA GARANTÍA POR FUGAS DE AGUA QUEDA ANULADA SI LA TEMPERATURA AMBIENTE SUPERA LOS 75°F Y EL 55% DE HUMEDAD RELATIVA, Y EL DESAGÜE DEL APARATO NO ESTÁ CONECTADO DIRECTAMENTE A UN DESAGÜE DE PISO.***

# General Information

---

Omcan Manufacturing and Distributing Company Inc., Food Machinery of America, Inc. dba Omcan and Omcan Inc. are not responsible for any harm or injury caused due to any person's improper or negligent use of this equipment. The product shall only be operated by someone over the age of 18, of sound mind, and not under the influence of any drugs or alcohol, who has been trained in the correct operation of this machine, and is wearing authorized, proper safety clothing. Any modification to the machine voids any warranty, and may cause harm to individuals using the machine or in the vicinity of the machine while in operation.

## CHECK PACKAGE UPON ARRIVAL

Upon receipt of an Omcan shipment please inspect for external damage. If no damage is evident on the external packaging, open carton to ensure all ordered items are within the box, and there is no concealed damage to the machine. If the package has suffered rough handling, bumps or damage (visible or concealed), please note it on the bill of lading before accepting the delivery and contact Omcan within 24 hours, so we may initiate a claim with the carrier. A detailed report on the extent of the damage caused to the machine must be filled out within three days, from the delivery date shown in the shipping documents. Omcan has no recourse for damaged products that were shipped collect or third party.

**Before operating any equipment, always read and familiarize yourself with all operation and safety instructions.**

Omcan would like to thank you for purchasing this machine. It's of the utmost importance to save these instructions for future reference. Also save the original box and packaging for shipping the equipment if servicing or returning of the machine is required.

---

Omcan Fabrication et distribution Compagnie Limitée et Food Machinery d'Amérique, dba Omcan et Omcan Inc. ne sont pas responsables de tout dommage ou blessure causé du fait que toute personne ait utilisé cet équipement de façon irrégulière. Le produit ne doit être exploité que par quelqu'un de plus de 18 ans, saine d'esprit, et pas sous l'influence d'une drogue ou d'alcool, qui a été formé pour utiliser cette machine correctement, et est vêtu de vêtements de sécurité appropriés. Toute modification de la machine annule toute garantie, et peut causer un préjudice à des personnes utilisant la machine ou des personnes à proximité de la machine pendant son fonctionnement.

## VÉRIFIEZ LE COLIS DÈS RÉCEPTION

Dès réception d'une expédition d'Omcan veuillez inspecter pour dommages externes. Si aucun dommage n'est visible sur l'emballage externe, ouvrez le carton afin de s'assurer que tous les éléments commandés sont dans la boîte, et il n'y a aucun dommage dissimulé à la machine. Si le colis n'a subi aucune mauvaises manipulations, de bosses ou de dommages (visible ou cachée), notez-le sur le bond de livraison avant d'accepter la livraison et contactez Omcan dans les 24 heures qui suivent, pour que nous puissions engager une réclamation auprès du transporteur. Un rapport détaillé sur l'étendue des dommages causés à la machine doit être rempli dans un délai de trois jours, à compter de la date de livraison indiquée dans les documents d'expédition. Omcan n'a aucun droit de recours pour les produits endommagés qui ont été expédiés ou cueilli par un tiers transporteur.



# General Information

---

Avant d'utiliser n'importe quel équipement, toujours lire et vous familiariser avec toutes les opérations et les consignes de sécurité.

Omcan voudrais vous remercier d'avoir choisi cette machine. Il est primordial de conserver ces instructions pour une référence ultérieure. Également conservez la boîte originale et l'emballage pour l'expédition de l'équipement si l'entretien ou le retour de la machine est nécessaire.

Omcan Empresa De Fabricacion Y Distribucion Inc. Y Maquinaria De Alimentos De America, Inc. dba Omcan y Omcan Inc. no son responsables de ningun daño o perjuicio causado por cualquier persona inadecuada o el uso descuidado de este equipo. El producto solo podra ser operado por una persona mayor de 18 años, en su sano juicio y no bajo alguna influencia de droga o alcohol, y que este ha sido entrenado en el correcto funcionamiento de esta máquina, y ésta usando ropa apropiada y autorizada. Cualquier modificación a la máquina anula la garantía y puede causar daños a las personas usando la máquina mientras esta en el funcionamiento.

## REVISE EL PAQUETE A SU LLEGADA

Tras la recepcion de un envio Omcan favor inspeccionar daños externos. Si no hay daños evidentes en el empaque exterior, Habra el carton para asegurarse que todos los articulos solicitados estén dentro de la caja y no encuentre daños ocultos en la máquina. Si el paquete ha sufrido un manejo de poco cuidado, golpes o daños (visible o oculto) por favor anote en la factura antes de aceptar la entrega y contacte Omcan dentro de las 24 horas, de modo que podamos iniciar una reclamación con la compañía. Un informe detallado sobre los daños causados a la máquina debe ser llenado en el plazo de tres días, desde la fecha de entrega que se muestra en los documentos de envío. Omcan no tiene ningun recurso por productos dañados que se enviaron a recoger por terceros.

Antes de utilizar cualquier equipo, siempre lea y familiarizarse con todas las instrucciones de funcionamiento y seguridad.

Omcan le gustaría darle las gracias por la compra de esta máquina. Es de la mayor importancia para salvar estas instrucciones para futuras consultas. Además, guarda la caja original y el embalaje para el envío del equipo si servicio técnico o devolución de la máquina que se requiere.

# Safety and Warranty

---

Please pay close attention to the safety notices in this section. Disregarding these notices may lead to serious injury and can damage the unit.

## CAUTION FOR SAFETY

1. Leave enough space from the wall to the cabinet and the ceiling; do not place the back of the unit against the wall.

# ***Safety and Warranty***

---

**Caution: keep a minimum of 20cm from the cabinet and the wall.**

2. Please keep other objects away from the unit that may cause a fire.
3. Do not store flammable or combustible materials near the unit.
4. Only connect to a grounded single phase connection.

**Caution: Do not connect grounding wire to a water or gas pipe.**

5. Handle with caution during transportation, the unit can only be leaned a maximum of 45°.
6. When encountering problems, please refer to the Troubleshooting section or call Omcan.

**Danger: Flammable refrigerant used. Do not use mechanical devices to defrost the unit. Do not puncture the refrigerant tubing. To be repaired only by trained service technicians.**

**Caution: Flammable refrigerant used. Consult repair manual/owners guide before attempting to service this unit. All safety precautions must be followed.**

**Caution: Dispose of properly in accordance with federal or local regulations. Flammable refrigerant used.**

**Caution: Follow handling instructions carefully.**

**Caution: Ensure all ventilation openings are unobstructed.**

**Caution: Servicing shall be done by authorized service personnel, so as to minimize the risk of injury due to incorrect parts or improper service.**

## **ATTENTION**

- To minimize shock and fire hazards, be sure not to overload outlet. Please designate one outlet for your unit.
- Do not use extension cords.
- Do not put your hands under the unit when the unit is required to be moved.
- When the unit is not in use for a long period of time, please unplug the unit from the outlet.
- After unplugging the unit, wait at least 10 minutes before re-plugging it. Failure to do so could cause damage to the compressor.

## **UNPLUG CORD**

- To minimize shock and fire hazards, please do not plug or unplug the cord with wet hands.
- During maintenance and cleaning, please unplug the unit..

## **PROPER GROUNDING REQUIRED**

- To minimize shock and fire hazards, make sure that the unit is properly grounded.

## **PROHIBITION**

- Do not attempt to remove or repair any component unless instructed by Omcan.
- Make sure that the unit is not resting on or against the electrical cord and plug.
- To minimize personal injury, do not hang on the doors.
- Do not store any flammable or explosive material inside the unit.



# Safety and Warranty

---

- Do not attempt to alter or tamper with the electrical cord.

**RESIDENTIAL USERS:** Vendor assumes no liability for parts or labor coverage for component failure or other damages resulting from installation in non-commercial or residential applications. The right is reserved to deny shipment for residential usage; if this occurs, you will be notified as soon as possible.

## 1 YEAR PARTS AND LABOUR WARRANTY

Within the warranty period, contact Omcan Inc. at 1-800-465-0234 to schedule an Omcan authorized service technician to repair the equipment locally.

Unauthorized maintenance will void the warranty. Warranty covers electrical and part failures, not improper use.

Please see <https://omcan.com/disclaimer> for complete info.

### WARNING:

The packaging components are classified as normal solid urban waste and can therefore be disposed of without difficulty.

In any case, for suitable recycling, we suggest disposing of the products separately (differentiated waste) according to the current norms.

**DO NOT DISCARD ANY PACKAGING MATERIALS IN THE ENVIRONMENT!**

# Technical Specifications

## STANDING REFRIGERATORS

Model	RE-CN-0041E-HC	RE-CN-0023E-HC	RE-CN-0045E-HC	RE-CN-0009E-HC
Temperature Range	0.5 - 5°C / 32.9 - 41°F			
Max Ambient Temp Rating	24°C / 75°F			
Power	1/3HP	1/2HP	1/3HP	1/4HP
Electrical	115V / 60Hz / 1			
Current	3.8A	3.96A	4.3A	2.9A
Refrigerant	R290			
Isolation Material	Cyclopentane			
Cooling System	Ventilated			
Number of Shelves	6	4	8	4
Shelf Capacity	88.2 lbs. / 40 kgs.			
Exterior Dimensions	54" x 32.2" x 82.5" 1371 x 818 x 2095mm	28.3" x 31.9" x 83.9" 720 x 810 x 2130mm	53.1" x 31.9" x 79.9" 1350 x 810 x 2030mm	21.7" x 21.7" x 63" 550 x 550 x 1600mm
Interior Dimensions	49.4" x 27.1" x 53.5" 1255 x 688 x 1360mm	25.2" x 28.3" x 62.5" 640 x 720 x 1588mm	50" x 28.3" x 61.9" 1270 x 720 x 1573mm	18.9" x 18.3" x 46.1" 480 x 465 x 1170mm
Packing Dimensions	56.5" x 34.6" x 84.4" 1435 x 880 x 2145mm	30.1" x 35.6" x 85.4" 765 x 905 x 2170mm	55.9" x 33.5" x 84.6" 1420 x 850 x 2150mm	23.6" x 24.8" x 69.1" 600 x 630 x 1755mm
Net Volume	1330.9 L / 47 cu.ft.	640 L / 22.6 cu.ft.	1268.6 L / 44.8 cu.ft.	257.7 L / 9.1 cu.ft.
Weight	469.6 lbs. / 213 kgs.	319.7 lbs. / 145 kgs.	436.5 lbs. / 198 kgs.	189.6 lbs. / 86 kgs.
Packaging Weight	553.4 lbs. / 251 kgs.	352.7 lbs. / 160 kgs.	480.6 lbs. / 218 kgs.	224.9 lbs. / 102 kgs.
Item Number	59026	59036	59032	59033

## Installation

### IMPORTANT!!! PLEASE READ BEFORE INSTALLATION

- If the unit has recently been transported, please let the unit stand upright for a minimum of 24 hours before plugging it in.
- Make sure that the unit drops down to the desired temperature before loading the unit with product.
- Make sure that there is proper ventilation around the unit in the area where it will operate.
- Make sure all accessories are installed (shelves, casters, ect.) before plugging in the unit.
- Please read through the manual in its entirety.

### CABINET LOCATION GUIDELINES

#### INSTALL THE UNIT ON A STRONG AND LEVELED SURFACE

- Unit may make unpleasant noises if surface is uneven.



# Installation

---

- Unit may malfunction if surface is uneven.

## **INSTALL THE UNIT IN AN INDOOR, WELL VENTILATED AREA**

- Unit performs more efficiently in a well ventilated area.
- For best performance, please maintain a clearance of 4" from the back of the unit.
- Not to be used outdoors.

## **AVOID INSTALLATION IN A HIGH HUMIDITY AND/OR DUSTY AREA**

- Humidity can cause the unit to rust and decrease efficiency of the unit.
- Dust collected on the condenser coil will cause the unit to malfunction. Clean the condenser at least once a month with a brush or clean cloth.

## **SELECT A LOCATION AWAY FROM HEAT AND MOISTURE-GENERATING EQUIPMENT**

- High ambient temperatures will cause the compressor to overwork, leading to higher energy bills and gradual breakdown of the unit.

## **ELECTRICAL**

Please ensure that the required voltage of the compressor is being supplied at all times. Low or high voltage can detrimentally affect the refrigeration unit. All units should be plugged into a grounded a properly-sized electrical outlet with appropriate overcurrent protection. Please refer to the electrical requirements on the rating plate. Please make sure that your unit has its own dedicated outlet. Do not use an extension cord.

# Maintenance

---

## **CLEANING THE CONDENSER COIL**

- For efficient operation, it is important that the condenser surface be kept free of dust, dirt and lint.
- We recommend cleaning the condenser coil and fins at least once per month.
- Clean with a commercial condenser coil cleaner. Brush the condenser fins from top to bottom, not side to side.
- After cleaning, straighten any bent condenser fins with a fin comb.

## **CLEANING THE FAN BLADES AND MOTOR**

If necessary, clean the fan blades and motor with a soft cloth. If it is necessary to wash the fan blades, cover the fan motor to prevent moisture damage.

## **CLEANING THE INTERIOR OF THE UNIT**

- When cleaning the cabinet interior, use a solvent of warm water and mild soap.
- Do not use steel wool, caustic soap, abrasive cleaners, or bleach that may damage the stainless steel

# Maintenance

---

surface.

- Wash door gaskets on a regular basis, preferably weekly. Simply remove door gasket from the frame of the door, soak in warm water and soap for thirty (30) minutes, dry with a soft cloth and replace.
- Check door gaskets for proper seal after they are replaced.
- Periodically remove the shelves and pilasters from the unit and clean them with mild soap and warm water. To remove the pilasters, first remove the shelves and shelf brackets. Then, simply lift the pilaster up and out.

**Warning: Disconnect power cord before cleaning any parts of the unit.**

# Troubleshooting

---

Problem	Possible Cause	Solution
Compressor not running.	Fuse blown or circuit breaker tripped.	Replace fuse or reset circuit breaker.
	Power cord unplugged.	Plug in power cord.
	Thermostat set too high.	Set thermostat to a lower temperature.
	Cabinet in defrost cycle.	Wait for defrost cycle to finish.
Condensing unit runs for long periods of time.	Excessive amount of warm product placed in cabinet.	Allow adequate time for product to cool down.
	Prolonged door opening or door ajar.	Ensure doors are closed when not in use. Avoid opening doors for long periods of time.
	Door gaskets not sealing properly.	Ensure gaskets are snapped in completely. Remove gaskets and wash with soap and water. Check condition of gaskets and replace if necessary.
	Dirty condenser coil.	Clean the condenser coil.
	Evaporator coil iced over.	Unplug unit and allow coil to defrost. Make sure thermostat is not set too cold. Ensure that the door gaskets are sealing properly.

# Troubleshooting

Cabinet temperature is too warm.	Thermostat set too warm.	Set thermostat to a lower temperature.
	Blocking air flow.	Re-arrange product to allow for proper air flow. Make sure there is at least 4" of clearance from evaporator.
	Excessive amount of warm product placed in cabinet.	Allow adequate time for product to cool down.
	Fuse blown or circuit breaker tripped.	Replace fuse or reset circuit breaker.
	Dirty condenser coil.	Clean the condenser coil.
	Prolonged door opening or door ajar.	Ensure doors are closed when not in use. Avoid opening doors for long periods of time.
	Evaporator coil iced over.	
Cabinet is noisy.	Loose parts.	Locate and tighten the loose parts.
	Tubing vibration.	Ensure tubing is free from contact with other tubing or components.



# Parts Breakdown

## Model RE-CN-0041E-HC 59026

Item No.	Description	Position	Item No.	Description	Position	Item No.	Description	Position
AF047	Cabinet for 59026	1	AF033	Left Air Guide Sheet for 59026	22	AF055	Condenser for 59026	44
AI376	Control Panel for 59026	2	AI371	Evaporator for 59026	23	AI374	Condenser Fan Motor for 59026	45
AF048	Front Grill for 59026	3	AF051	Inner Drain Pan for 59026	24	AA764	Condenser/Evaporator Fan Motor Blade for 59026	46
AI377	Right Door for 59026	4	AA969	Drain Hose for 59026	25	AA249	Condenser Fan Motor Cover for 59026	47
AB029	Gasket for 59026	5, 10	69703	Elbow Pipe for 59026	26	AB970	Outer Drain Pan for 59026	48
AA954	Upper Right Hinge Holder for 59026	6	AA970	Light Components for 59026	27	AF056	Back Grill for 59026	49
AA956	Bottom Right Hinge Holder for 59026	7	AF037	Evap Fan Motor Cover for 59026	28	AA124	Power Switch for 59026	50
AA955	Left/Right Spring Hinge for 59026	8, 13	26884	K Clip for 59026	29	AI375	Thermostat for 59026	51
AI370	Left Door for 59026	9	AA809	K Strip for 59026	30	AB977	Door Switch for 59026	52
AB032	Upper Left Hinge Holder for 59026	11	AF052	Back Brackets for 59026	31	AF046	Drain Plug for 59026	53
AB033	Bottom Left Hinge Holder for 59026	12	AA975	Shelf for 59026	32	26247	Caster without Brake for 59026	54
AA959	Hinge for 59026	14	AF053	Evaporator Cover for 59026	33	26246	Caster with Brake for 59026	55
AA197	Lock for 59026	15	AF040	Left Track for Assembling Panel for 59026	34	AA993	Power Plug Fitting Base for 59026	56
AF028	Lock Bolt for 59026	16	AF041	Right Track for Assembling Panel for 59026	35	AA216	Drain Tube for 59026	57
61471	Leg Supporter for 59026	17	AF054	Compressor Unit Installation Board for 59026	36	AA379	Temperature Probe for 59026	58
AF825	Evaporator Fan Motor for 59026	18	AI372	Compressor for 59026	37	AA197	Lock for 59026	59
AA962	Blade of Evaporator Fan Motor for 59026	19	AI373	Compressor Starting Components for 59026	38 - 41	AA805	Power Cord for 59026	60
AF031	Evaporator Fan Motor Holder for 59026	20	AB595	Filter Fixer for 59026	42	AF057	Cabinet Supporter for 59026	61
AF032	Right Air Guide Sheet for 59026	21	AB594	Filter for 59026	43			



# Parts Breakdown

## Model RE-CN-0023E-HC 59036

Item No.	Description	Position	Item No.	Description	Position	Item No.	Description	Position
AB953	Right Track for Installation Board for 59036	1	AA748	Shelf Tag for 59036	19	AA863	Fixer for Probe for 59036	37
AB954	Castor Supporter for 59036	2	AA722	LED Light for 59036	20	AA759	Evaporator for 59036	38
AA135	Power Cord for 59036	3	AB959	Outer Drain Pan for 59036	22	AB077	Condenser Fan Cover for 59036	39
AA703	Power Cord Cover for 59036	4	AB960	Left Track for Installation Board for 59036	23	AA712	Inner Drain Tube Connector for 59036	40
AA743	4" Caster without Brake for 59036	5	AB961	Compressor Unit Installation Board for 59036	24	AA528	Drain Hose for 59036	41
AA584	Caster with Break for 59036	6	AA713	Bottom Right Hinge Holder for 59036	25	AI826	Air Pipe Protection Board for 59036	42
AB955	Back Grill for 59036	7	AA714	Hinge Axis for 59036	26	AA695	Glass Door Handle for 59036	43
AA216	Drain Tube for 59036	8	AA715	Axis Cover for 59036	27	AB966	Upper Right Hinge Holder for 59036	44
AA687	Drain Pipe Cover for 59036	9	AA753	Light Box Plate for 59036	28	AA761	Glass Door for 59036	45
AA686	Plastic Drain Pipe with Fixer for 59036	10, 11	AA754	Light Box Frame for 59036	29	AA762	Gasket for 59036	46
AB109	Thermostat for 59036	12	AA721	LED in Light Box for 59036	30	AI395	Compressor for 59036	47
AA362	LED Light Switch for 59036	13	AA711	LED Power Supply for 59036	31	AI321	Condenser Fan Motor for 59036	49
AA124	Power Switch for 59036	14	AI382	Temperature Probe for 59036	32	AB594	Filter for 59036	51
AB956	Front Grill for 59036	15	AI825	Evaporator Cover for 59036	33	AB595	Filter Fixer for 59036	52
AB957	K Strip for 59036	16	AA764	Condenser/Evaporator Fan Motor Blade for 59036	34, 50	AA249	Condenser Fan Motor Cover for 59036	53
26884	K Clip for 59036	17	AI381	Evaporator Installation Bracket for 59036	35	AA250	Condenser for 59036	54
AA747	Shelf for 59036	18	AF825	Evaporator Fan Motor for 59036	36	AA214	Thermostat Water Proof Cover for 59036	55

# Parts Breakdown

Model RE-CN-0045E-HC 59032

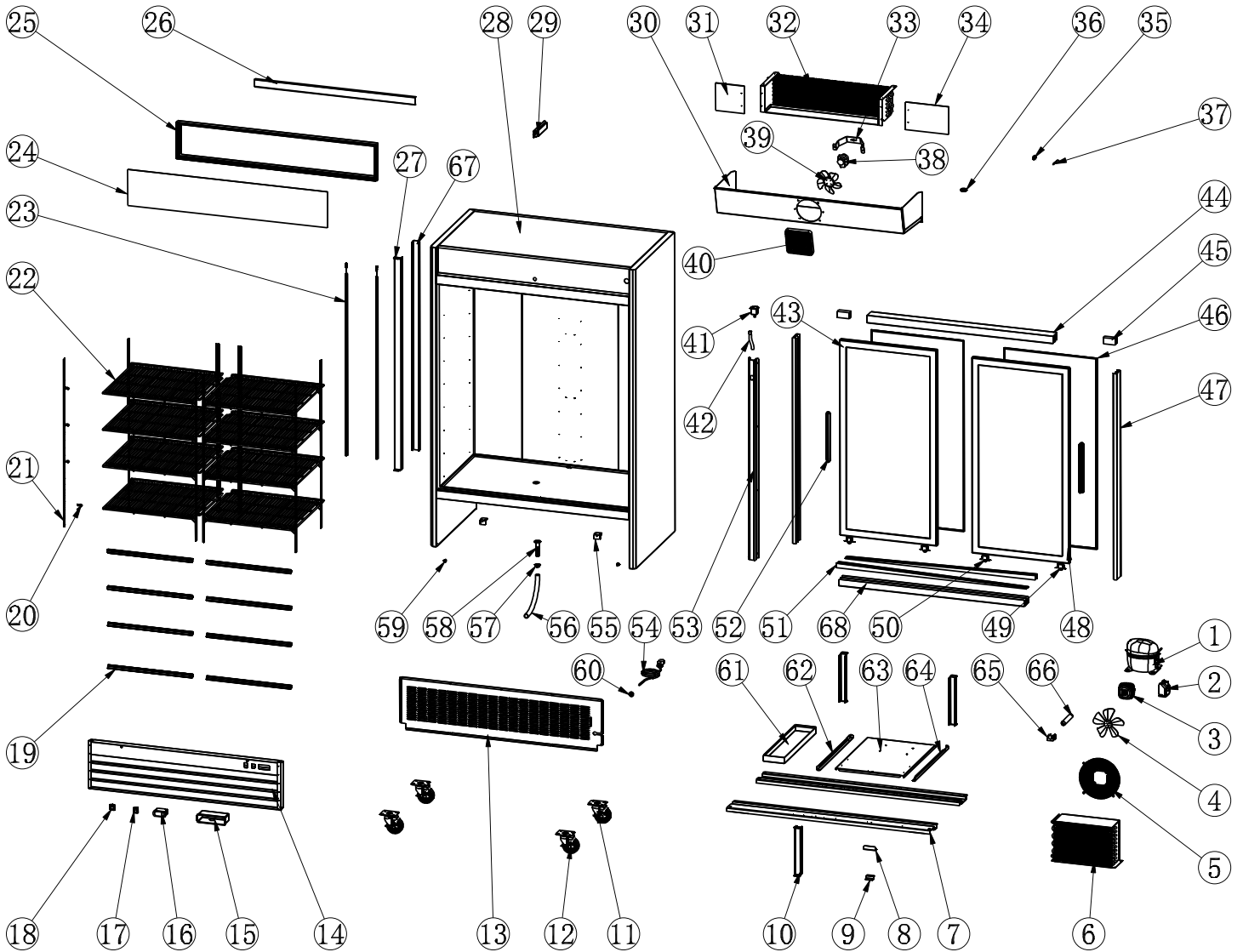



# Parts Breakdown

## Model RE-CN-0045E-HC 59032

Item No.	Description	Position	Item No.	Description	Position	Item No.	Description	Position
AE876	Compressor for 59032	1	AA780	Light Plate for 59032	24	AA801	Bigger Wheel for Door for 59032	49
AI321	Condenser Fan Motor for 59032	3, 38	AI378	Light Box for 59032	25	AA802	Smaller Wheel for Door for 59032	50
AA764	Condenser/Evaporator Fan Motor Blade for 59032	4, 39	65106	LED Light in Lamp Box for 59032	26	AG052	Door Track for 59032	51
AA249	Condenser Fan Motor Cover for 59032	5	AI379	Middle Beam Sheet for 59032	27	62363	Door Handle for 59032	52
AA300	Condenser for 59032	6	AA787	LED Power Supply for 59032	29	AI383	Air Pipe Protection Board for 59032	53
AE878	Caster Supporter for 59032	7	AI380	Evaporator Cover for 59032	30	AA805	Power Cord for 59032	54
AB974	Handle for Installation Board for 59032	8	AE887	Left End Plate for Evaporator for 59032	31	AG053	Grill Fixer for 59032	55
AA304	Installation Board Limited Block for 59032	9	AG551	Evaporator for 59032	32	AA216	Drain Tube for 59032	56
AE879	Support Rod for 59032	10	AI381	Evaporator Installation Bracket for 59032	33	AA687	Drain Pipe Cover for 59032	57
AA743	4" Caster without Brake for 59032	11	AE888	Right End Plate for Evaporator for 59032	34	AA686	Plastic Drain Pipe with Fixer for 59032	58
AA584	Caster with Brake for 59032	12	AA863	Fixer for Probe for 59032	35	AA767	Front Grill Fixer for 59032	59
AE881	Back Grill for 59032	13	AA794	Power Cord Cover for 59032	36	AA703	Power Cord Cover for 59032	60
AG049	Front Grill for 59032	14	AI382	Temperature Probe for 59032	37	AB959	Outer Drain Pan for 59032	61
AA214	Thermostat Water Proof Cover for 59032	15	AB077	Condenser Fan Cover for 59032	40	AE892	Left Rail for Installation Board for 59032	62
AB109	Thermostat for 59032	16	AA712	Inner Drain Tube Connector for 59032	41	AE893	Installation Board for 59032	63
AA362	LED Light Switch for 59032	17	AA528	Drain Hose for 59032	42	AE894	Right Rail for Installation Board for 59032	64
AA124	Power Switch for 59032	18	AA766	Left Glass Door for 59032	43	AB595	Filter Fixer for 59032	65
AA777	Shelf Tag for 59032	19	AA796	Upper Cabinet Frame for 59032	44	AB594	Filter for 59032	66
26884	K Clip for 59032	20	AA797	Rubber Limited Block for 59032	45	AI384	Back Sheet of Middle Beam for 59032	67
AA809	K Strip for 59032	21	AA798	Seal Strip for 59032	46	AG050	Bottom Cabinet Frame for 59032	68
AA779	Shelf for 59032	22	AA799	Left/Right Cabinet Frame for 59032	47			
AA722	LED Light for 59032	23	AA800	Right Glass Door for 59032	48			

# Parts Breakdown

Model RE-CN-0009E-HC 59033

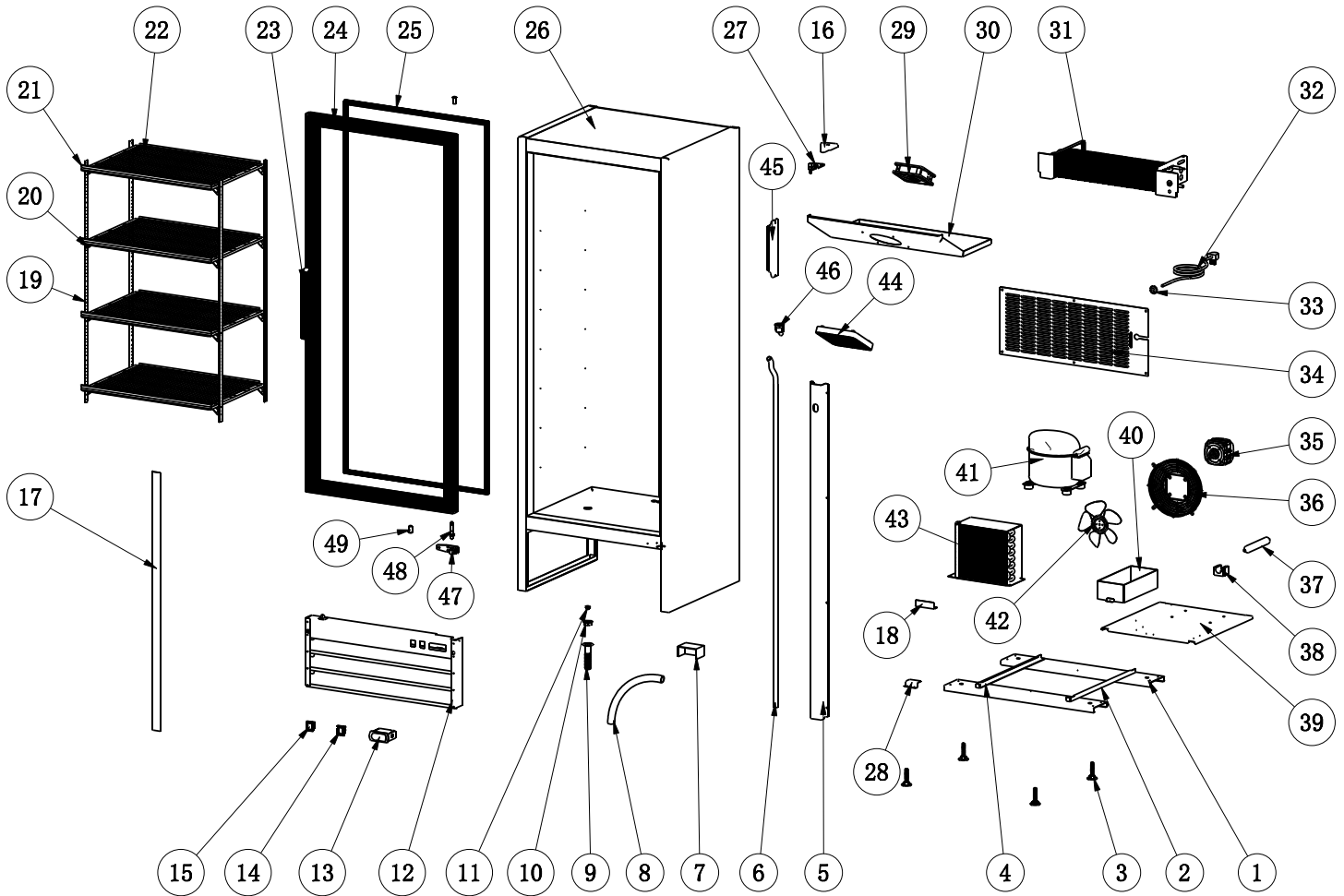

# Parts Breakdown

## Model RE-CN-0009E-HC 59033

Item No.	Description	Position	Item No.	Description	Position	Item No.	Description	Position
AE895	Castor Supporter for 59033	1	AB974	Handle for Installation Board for 59033	18	AF825	Evaporator Fan Motor for 59033	35
AE896	Right Track for Installation Board for 59033	2	AE900	K Strip for 59033	19	AA207	Condenser Fan Motor Cover for 59033	36
AA185	Leveling Feet for 59033	3	26884	K Clip for 59033	20	AB594	Filter for 59033	37
AE897	Left Track for Installation Board for 59033	4	AA693	Shelf Tag for 59033	21	AB595	Filter Fixer for 59033	38
AE898	Back Plate for 59033	5	AA694	Shelf for 59033	22	AE904	Compressor Unit Installation Board for 59033	39
AA528	Drain Hose for 59033	6	AA695	Glass Door Handle for 59033	23	AE905	Outer Drain Pan for 59033	40
AI385	Waterproof Cover of Thermostat for 59033	7	AA696	Glass Door for 59033	24	AI386	Compressor for 59033	41
AA216	Drain Tube for 59033	8	AA697	Glass Door Gasket for 59033	25	AA208	Condenser Fan Blade for 59033	42
AA686	Plastic Drain Pipe with Fixer for 59033	9, 10	AA699	Upper Right Hinge Holder for 59033	27	AA709	Condenser for 59033	43
AA687	Drain Pipe Cover for 59033	11	AA304	Installation Board Limited Block for 59033	28	AA710	Evaporator Fan Motor Cover for 59033	44
AE899	Front Grille for 59033	12	AA128	Condenser Fan Motor for 59033	29	AA711	LED Power Supply for 59033	45
AB109	Thermostat for 59033	13	AE902	Evaporator Cover for 59033	30	AA712	Inner Drain Tube Connector for 59033	46
AA362	LED Light Switch for 59033	14	AA702	Evaporator for 59033	31	AA713	Bottom Right Hinge Holder for 59033	47
AA124	Power Switch for 59033	15	AA135	Power Cord for 59033	32	AA714	Hinge Axis for 59033	48
AA689	Upper Hinge Cover for 59033	16	AA703	Power Cord Cover for 59033	33	AA715	Axis Cover for 59033	49
AA690	LED Light for 59033	17	AE903	Back Grill for 59033	34			

# Electrical Schematics

Model RE-CN-0041E-HC 59026

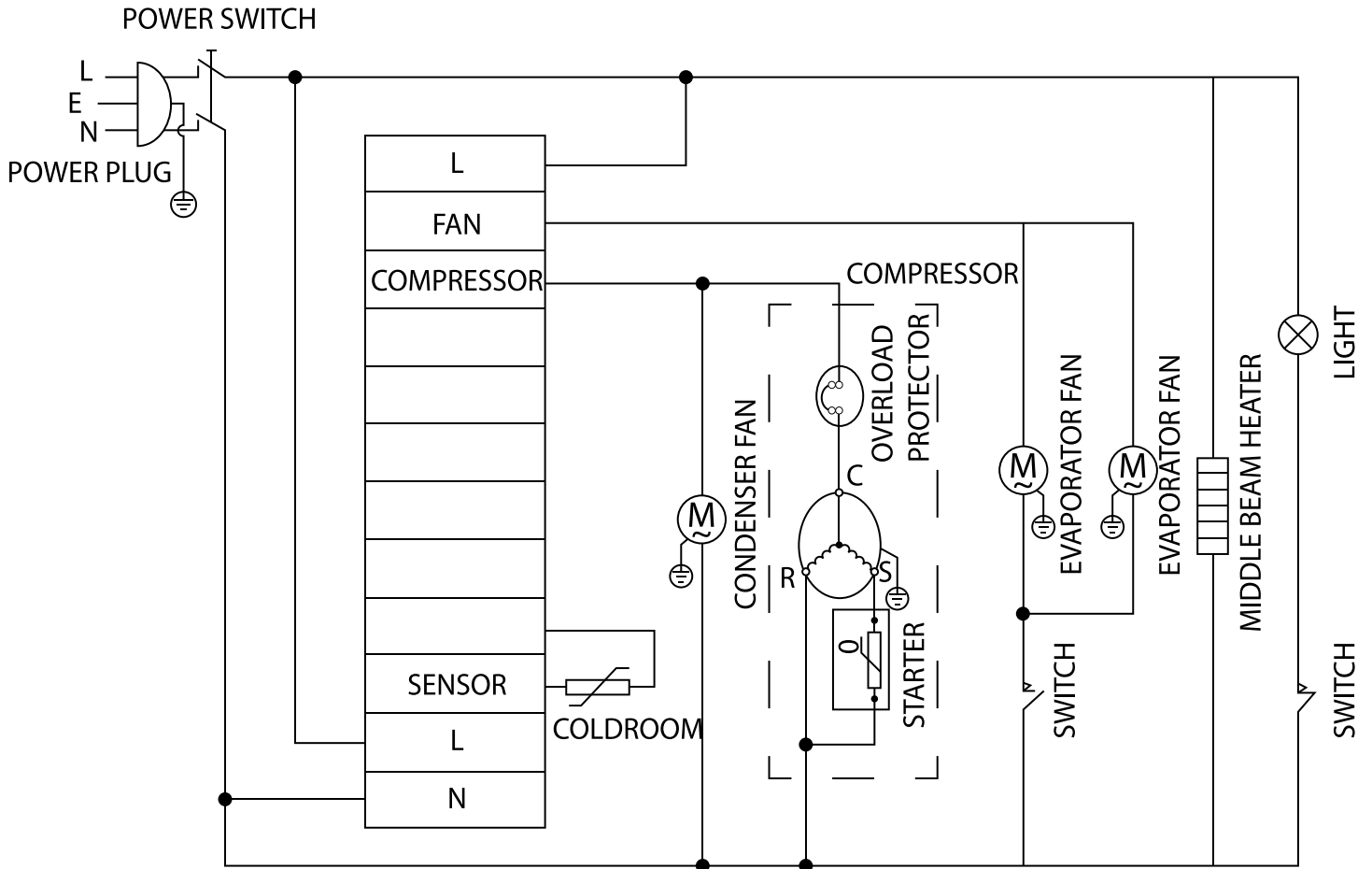

# Electrical Schematics

**Model RE-CN-0023E-HC** 59036

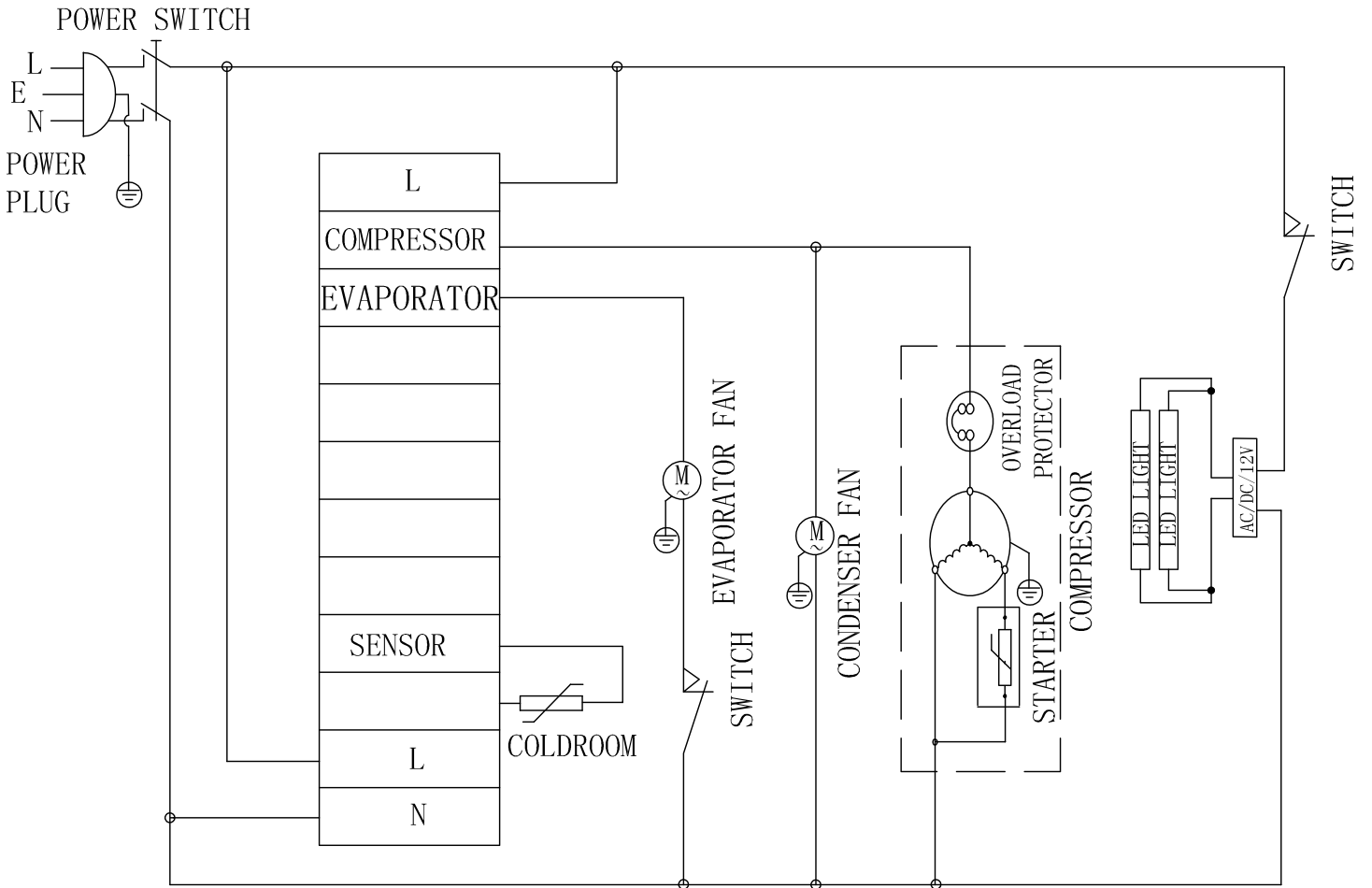

# Electrical Schematics

Model RE-CN-0045E-HC 59032

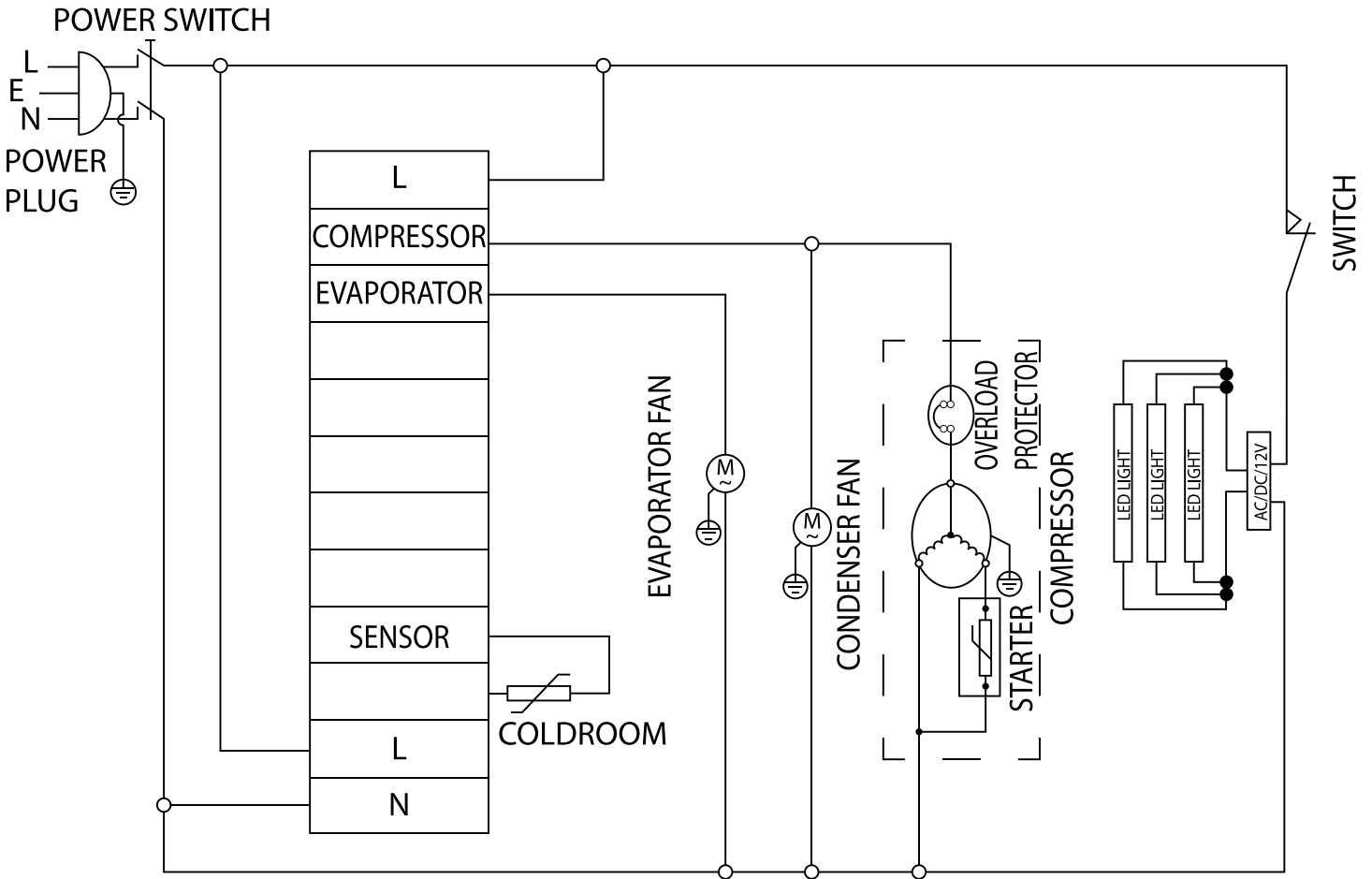

# Electrical Schematics

**Model RE-CN-0009E-HC 59033**

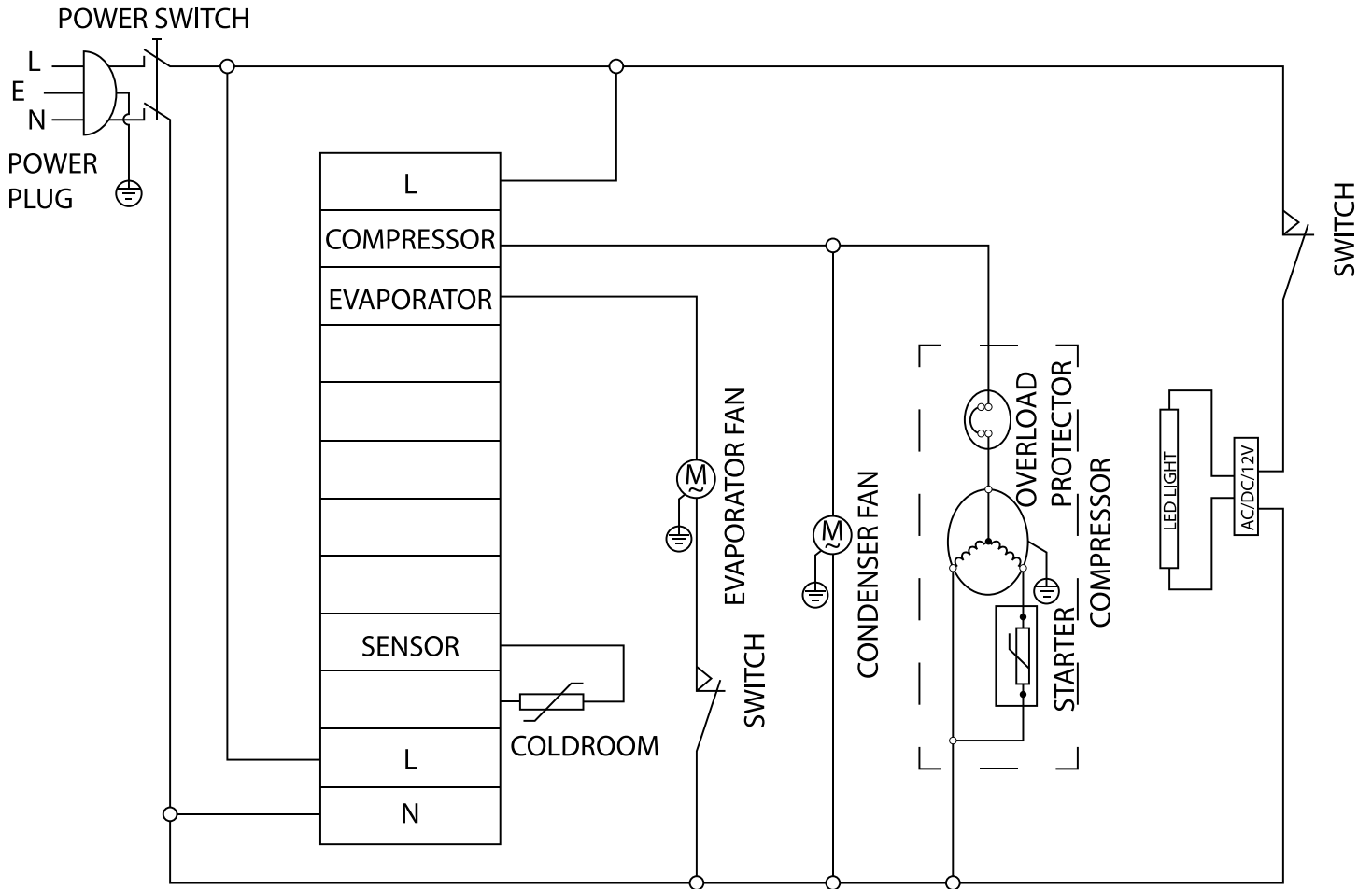











# Warranty Registration

Thank you for purchasing an Omcan product. To register your warranty for this product, complete the information below, tear off the card at the perforation and then send to the address specified below. You can also register online by visiting:

Merci d'avoir acheté un produit Omcan. Pour enregistrer votre garantie pour ce produit, complétez les informations ci-dessous, détachez la carte au niveau de la perforation, puis l'envoyer à l'adresse spécifiée ci-dessous. Vous pouvez également vous inscrire en ligne en visitant:

Gracias por comprar un producto Omcan usted. Para registrar su garantía para este producto, complete la información a continuación, cortar la tarjeta en la perforación y luego enviarlo a la dirección indicada a continuación. También puede registrarse en línea en:

<https://omcan.com/warranty-registration/>

For mailing in Canada

Pour postale au Canada

Por correo en Canadá

**OMCAN**

PRODUCT WARRANTY REGISTRATION

3115 Pepper Mill Court,

Mississauga, Ontario

Canada, L5L 4X5

For mailing in the US

Pour diffusion aux États-Unis

Por correo en los EE.UU.

**OMCAN**

PRODUCT WARRANTY REGISTRATION

4450 Witmer Industrial Estates, Unit 4,

Niagara Falls, New York

USA, 14305

*or email to: [service@omcan.com](mailto:service@omcan.com)*



Purchaser's Information

Name: \_\_\_\_\_

Address: \_\_\_\_\_

City: \_\_\_\_\_ Province or State: \_\_\_\_\_ Postal or Zip: \_\_\_\_\_

Country: \_\_\_\_\_

Dealer from which Purchased: \_\_\_\_\_

Dealer City: \_\_\_\_\_ Dealer Province or State: \_\_\_\_\_

Invoice: \_\_\_\_\_

Model Name: \_\_\_\_\_ Model Number: \_\_\_\_\_

Machine Description: \_\_\_\_\_

Date of Purchase (MM/DD/YYYY): \_\_\_\_\_

Would you like to extend the warranty?  Yes  No

Company Name: \_\_\_\_\_

Telephone: \_\_\_\_\_

Email Address: \_\_\_\_\_

Type of Company:

Restaurant  Bakery  Deli

Butcher  Supermarket  Caterer

Institution (specify): \_\_\_\_\_

Other (specify): \_\_\_\_\_

Serial Number: \_\_\_\_\_

Date of Installation (MM/DD/YYYY): \_\_\_\_\_

**Thank you for choosing Omcan | Merci d'avoir choisi Omcan | Gracias por elegir Omcan**



Since 1951 Omcan has grown to become a leading distributor of equipment and supplies to the North American food service industry. Our success over these many years can be attributed to our commitment to strengthen and develop new and existing relationships with our valued customers and manufacturers. Today with partners in North America, Europe, Asia and South America, we continually work to improve and grow the company. We strive to offer customers exceptional value through our qualified local sales and service representatives who provide convenient access to over 6,500 globally sourced products.

---

Depuis 1951 Omcan a grandi pour devenir un des “leaders” de la distribution des équipements et matériel pour l’industrie des services alimentaires en Amérique du Nord. Notre succès au cours de ces nombreuses années peut être attribué à notre engagement à renforcer et à développer de nouvelles et existantes relations avec nos clients et les fabricants de valeur. Aujourd’hui avec des partenaires en Amérique du Nord, Europe, Asie et Amérique du Sud, nous travaillons continuellement à améliorer et développer l’entreprise. Nous nous efforçons d’offrir à nos clients une valeur exceptionnelle grâce à nos ventes locales qualifiées et des représentants de service qui offrent un accès facile à plus de 6500 produits provenant du monde entier.

---

Desde 1951 Omcan ha crecido hasta convertirse en un líder en la distribución de equipos y suministros de alimentos en América del Norte industria de servicios. Nuestro éxito en estos años se puede atribuir a nuestro compromiso de fortalecer y desarrollar nuevas relaciones existentes con nuestros valiosos clientes y fabricantes. Hoy con socios de América del Norte, Europa, Asia y América del Sur, que trabajan continuamente para mejorar y crecer la empresa. Nos esforzamos por ofrecer a nuestros clientes valor excepcional a través de nuestro local de ventas y representantes de los servicios que proporcionan un fácil acceso a más de 6,500 productos con origen a nivel mundial.

